

2017

Incorporation of organization design in a value-based systems engineering framework

Benjamin Jekonia Kwasa
Iowa State University

Follow this and additional works at: <https://lib.dr.iastate.edu/etd>

 Part of the [Aerospace Engineering Commons](#)

Recommended Citation

Kwasa, Benjamin Jekonia, "Incorporation of organization design in a value-based systems engineering framework" (2017). *Graduate Theses and Dissertations*. 16062.
<https://lib.dr.iastate.edu/etd/16062>

This Dissertation is brought to you for free and open access by the Iowa State University Capstones, Theses and Dissertations at Iowa State University Digital Repository. It has been accepted for inclusion in Graduate Theses and Dissertations by an authorized administrator of Iowa State University Digital Repository. For more information, please contact digirep@iastate.edu.

Incorporation of organization design in a value-based systems engineering framework

by

Benjamin Jekonia Kwasa Kwasa

A dissertation submitted to the graduate faculty
in partial fulfillment of the requirements for the degree of
DOCTOR OF PHILOSOPHY

Major: Aerospace Engineering

Program of Study Committee:
Christina L. Bloebaum, Major Professor
Eliot Winer
Paul Componation
Ambar K. Mitra
Leifur Leifsson

Iowa State University
Ames, Iowa

2017

Copyright © Benjamin Jekonia Kwasa Kwasa, 2017. All rights reserved.

TABLE OF CONTENTS

TABLE OF CONTENTS.....	ii
LIST OF FIGURES	iv
LIST OF TABLES	vi
ACKNOWLEDGEMENTS	viii
ABSTRACT.....	ix
CHAPTER 1: INTRODUCTION.....	1
Motivation.....	1
Research Objectives	7
Organization of Dissertation	8
CHAPTER 2: BACKGROUND.....	10
Multidisciplinary Design Optimization.....	10
Value-Driven Design.....	13
Organization Design.....	15
CHAPTER 3: COMPLEX SYSTEM	20
CHAPTER 4: SATELLITE SYSTEM	24
CHAPTER 5: PRELIMINARY SATELLITE SYSTEM STUDY.....	27
Organization Structure Parameters.....	27
Change in Organization Structure	29
Deterministic Design.....	30
Stochastic Design	33
Results	36
CHAPTER 6: DETERMINISTIC DESIGN.....	43
Organization Parameters	43
Critical Path.....	44
Organization Structures.....	48
Coupling Strengths	53

Satellite System Organization Parameters	56
Satellite Organization Structures.....	60
CHAPTER 7: STOCHASTIC DESIGN	66
Organization Parameters	66
Uncertainty Analysis	67
Satellite System Organization Parameters	73
Satellite Uncertainty Analysis.....	74
CHAPTER 8: INFORMATION UNCERTAINTY	80
Discrete Information	81
Uncertainty Analysis	86
CHAPTER 9: SUMMARY, CONCLUSION AND FUTURE WORK	90
Summary and Conclusion	90
Future Work	90
REFERENCES	92
APPENDIX A SATELLITE SYSTEM VARIABLES AND PARAMETERS	98
APPENDIX B SAMPLE SYSTEM DESIGN SPACE SURVEY	108
APPENDIX C PROBABILITY DISTRIBUTION UPDATING	117

LIST OF FIGURES

	Page
Figure 2.1: An MDF formulation of a complex system for optimization	11
Figure 2.2: A Representation of Two Coupled Subsystems A and B	12
Figure 2.3: Global Sensitivity Equation for the Coupled System	12
Figure 2.4: A VDD Approach to the Design of LSCESs	14
Figure 2.5: Primary Organization Breakdown	15
Figure 2.6: Basic Hierarchical Organization Structure	17
Figure 2.7: Basic Organization Structure Showing Both Vertical and Lateral Couplings	17
Figure 3.1: Sample Complex System Decomposition	20
Figure 3.2: A Complex System's Component-Based DSM	22
Figure 4.1: Communication Satellite System Consisting of Ground Station, Launch Vehicle and Satellite	24
Figure 4.2: Hierarchical Decomposition of a Communication Satellite System	25
Figure 4.3: Attribute-Based DSM of Satellite System	26
Figure 5.1: Probability Distributions of Net Present Profit for Design Under Uncertainty	40
Figure 6.1: Activity Flow Chart for Critical Path Identification	44
Figure 6.2: Activity Flow Chart for Critical Path Identification with Coupled Subsystems	45
Figure 6.3: Pure Hierarchy Structure	47
Figure 6.4: Completely Mirrored Structure	48
Figure 6.5: Partially mirrored structure with no direct link from A211 to A231	49

Figure 6.6:	Change in Value for Organization Structures as Presented in Appendix B.....	51
Figure 6.7:	Hierarchical Decomposition of Communication Satellite System	56
Figure 7.1:	System Value with Uncertainty in Specialization of S24	67
Figure 7.2:	Time Dependent System Value with Uncertainty in Specialization of S24 ...	67
Figure 7.3:	System Value with Uncertainty in Specialization of S12	68
Figure 7.4:	Time Dependent System Value with Uncertainty in Specialization of S12 ...	69
Figure 7.5:	System Values for Uncertainty in Subsystems S12 and S24	70
Figure 7.6:	Time Dependent System Values for Uncertainty in Subsystems S12 and S24	70
Figure 7.7:	System Values for Uncertainty in Coordination Tasks	71
Figure 7.8:	Time Dependent System Values for Uncertainty in Coordination Tasks	71
Figure 7.9:	Coordination Effort within Organization Structures	75
Figure 7.10:	Satellite System Development Time	76
Figure 7.11:	Satellite System Net Present Profit	77
Figure 8.1:	Sample Complex System Decomposition	81
Figure 8.2:	System Attributes	81
Figure 8.3:	System Value with Variation of Confidence in Information	84
Figure 8.4:	No. of iterations with Variation of Confidence in Information	84
Figure 8.5:	Design Variable X_1 Probability Distributions	86
Figure 8.6:	Mirrored Structure System Value Probability Distributions	87
Figure 8.7:	Pure Hierarchy System Value Probability Distributions	87

LIST OF TABLES

	Page
Table 5.1: Subsystem level 2 normalized attribute sensitivities	32
Table 5.2: Case studies performed to test the impact of information disruption	34
Table 5.2: Net present profit values for single decision maker information disruption	36
Table 5.4: Net present profit values for team decision maker information disruption	38
Table 5.5: Mean net present profit values for structure change under uncertainty	38
Table 6.1: Organization Parameters for the Complex	47
Table 6.2: Complex System Value with Different Structures	50
Table 6.3: Complex System Value under Coupling Suspension	53
Table 6.4: Subsystem Level Coordination Cost and Time Allocation	58
Table 6.5: Subsystem Specialization Cost and Time Allocation	58
Table 6.6: Pure Hierarchy Task Execution Count	60
Table 6.7: Pure Hierarchy Satellite System Value	61
Table 6.8: Mirrored Task Execution Count	62
Table 6.9: Mirrored Structure Satellite System Value	63
Table 7.1: Organization Parameter Peak Values	66
Table 7.2: Satellite Organization Peak Task Values	72

Table 7.3: Task Execution for Satellite Subsystems	74
Table 7.4: Satellite System Uncertainty Evaluation	76
Table 8.1: System Value with Complete Trust	82
Table 8.2: System Value with No Trust	83
Table 8.3: System Value with Varying Trust	83

ACKNOWLEDGEMENTS

I'd like to immediately thank God for this entire journey and for the people I am about to mention as well as those I will forget to mention.

To Dr. Christina L. Bloebaum, I am very grateful for the opportunity you provided me to pursue this PhD. Thank you for the mentorship you have provided over the years and I look forward to a continued friendship.

I'd like to sincerely thank my committee members, Dr. Eliot Winer, Dr. Paul Componation, Dr. Ambar Mitra and Dr. Leifur Leifsson for the guidance, time and mentorship provided through various experiences. Thank you, Dr. Mitra, for inspiring a desire to teach generations to come.

Without all the laughs and frustrations shared with my lab mates (MODELers), I would definitely not be here. To Rao (Dr. Kannan), thank you for your continued friendship and constantly setting the pace throughout my time in this program.

My parents and siblings have sacrificed more than I can possibly ever imagine or know and for that I am forever grateful for the overwhelming support and encouragement. Victoria, my better half, thank you very much for putting up with me while you went through vet school. Your love, patience and selflessness have seen me through the toughest of times. God truly works through you. I look forward to the adventures that lay ahead.

ABSTRACT

The design of Large-Scale Complex Engineered Systems (LSCESs) is an undertaking that requires large organizations made up of several teams of individuals, often spread over a significant geographical area. The structures of these organizations affect the design process of these engineered systems where design processes affect the products on which they are applied. Previous work has aptly demonstrated the improvements in design products where Value-Driven Design (VDD) is practiced, by capturing stakeholder preferences in value functions when using Multidisciplinary Design Optimization (MDO) frameworks to design complex systems. Organization structures, which are an essential part of Organization Design (OD), have been studied to understand the role that these structures play on resource management and utilization.

This research invokes the augmentation of systems engineering by the inclusion of OD via the addition of organization structure attributes and parameters to the value function for complex engineered systems. This allows for a platform where system design involves an objective evaluation of systems where the systems are defined not only by their physics-based characteristics but also by the processes that are used to design these very systems. Further, information on coupling strengths is investigated as a means to gain insight on how coupling suspension affects system value where the value function of a system includes organization attributes and parameters as well as traditional physics-based parameters, variables and attributes. Finally, this work proposes the capturing of trust placed on information by decision makers and how that affects the overall system value given the contribution of product and process as mentioned above.

CHAPTER 1: INTRODUCTION

Motivation

Large-Scale Complex Engineered Systems (LSCESs) provide, in part, solutions to complex problems. These LSCESs are also used to explore the universe to improve our understanding and therefore they provide secondary and tertiary solutions to complex societal challenges as spinoffs[1]. Advancements in engineering technology are a major driver for the rapid increase in globalization today. This globalization has fostered an environment for the continued emergence of complex problems. The result is an increase in the demand for innovative solutions to address these complex problems[2, 3]. The solutions are complex in nature and have led to a rise in the development of LSCESs. There are several challenges that plague LSCESs. This is evidenced by the creation of the Systems Sciences program by the National Science Foundation (NSF). The Systems Science program was created to address numerous challenges faced in the development of complex engineered systems[4, 5]. Workshops held by both the National Aeronautics and Space Administration (NASA) and the NSF highlight the need for innovative solutions to address the challenges that plague the design of complex engineered systems, particularly LSCESs[6]. These LSCESs are characterized in part by the large costs associated with their design and development, the number of components that make up the system, the complex behaviors that are a result of the interactions that exist amongst the components that make up these systems, and the duration required to complete their design and development[2]. These characteristics of LSCESs are also a source of a number of challenges that are associated with their design, development, operation, and retirement.

Part of the challenges associated with LSCESs arises from the need of these systems to interact with other LSCESs in their operational environment in order to successfully perform

required objectives[1, 3, 7]. These interactions can be represented as physics-based interfaces or organizational interfaces. The physics-based interfaces present challenges associated with the compatibility of the physics-based characteristics of the system interfaces. This means that various components that make up the entire system need to be designed to work seamlessly with other components. Another challenge is in the tradeoffs that must be made between parts of the system to ensure the delivery of a viable system. An example of an aerospace system would be a naval aircraft carrier which has physical interaction with naval aircrafts. This shared interface increases the complexity of these engineered systems. Another source of challenges faced during the design and development of LSCESs stems from LSCESs being a composite of other LSCESs. The national power grid network is an example of an LSCES that is a composite of other LSCESs. It consists of three main parts: power generation, power transmission, and power consumption[8]. As the first part, the power generation is a collection of a number of LSCESs which include geothermal power plants, nuclear power plants, and hydroelectric power plants. These systems are responsible for the production of electric energy. Another portion of the power generation subsystem of the power grid is the step up transformers which are needed to increase the transmission voltage thereby reducing the resistance present in transmission lines for a given current. The power transmission portion of the power grid consists of a network of transmission lines throughout the United States which are part of a number of systems known as interconnections[8]. These interconnections are responsible for the relaying of electricity from the various generation systems throughout the network to the distribution centers that are part of the power consumption subsystem of the power grid. The power consumption is the third part of the power grid. It includes the various consumers which could be primary (large commercial entities) or secondary consumers (residential and small commercial entities). The various entities that make

up the subsystems of the power grid are all LSCESs themselves. A jetliner such as the Boeing 747 is an example of an aviation LSCES within the realm of aerospace engineering. The aircraft is an aggregate of components which include the main plane (wings), the tail plane (empennage), the fuselage, the landing gear and the power plant (engines). These are systems in themselves which can be further decomposed to material components, electrical systems, and control systems amongst others. The decomposition of the power grid along with the decomposition of the Boeing 747 allows for an introductory understanding of the physics-based complexity of LSCESs.

In addition to the aforementioned characteristics of LSCESs, they require a large amount of man hours which are made available in large organizations that are responsible for their design and development. This is made possible by a collection of thousands and even tens of thousands of individuals working toward a collective goal present within a parent organization[1, 9, 10]. Where there is a need for multiple LSCESs to interact, there is a need for the corresponding parent organizations to interact. Each organization that undertakes design and development of LSCESs is characterized by the rules and regulations set in place to govern the collaborative work amongst individuals and groups of individuals that make the teams present in the organization. These rules and regulations dictate the authorized communication between teams and thus define the structure of the organizations[10, 11]. All organizations have an organization structure, some of which are unique to an organization, established to create an environment conducive to the guidance of the collaborative effort necessary within the organization. LSCESs are unique in that they demand similarly large organizations to create them.

All organizations have an organization structure, some of which are unique to an organization, established to create an environment conducive to the guidance of the collaborative effort necessary within the organization. LSCESs are unique in that they demand similarly large

organizations to create them. As an example, both The Boeing Company (Boeing) and The National Aeronautics and Space Administration (NASA) undertake the design and development of LSCESs. Boeing as of March 30th, 2017 has 146,962 employees with 74,196 under the commercial airplanes division, 45,926 in the defense, space and security division, and 26,948 employees under the corporate branch of the company[12]. NASA as of April 1st, 2017 has 17,435 employees, 16,594 of whom are on full-time appointments. Additionally, NASA has just over 40,000 contractors and grantees[13].

The interfaces present in organization structures adopted by such aforementioned organizations are part of the infrastructure set in place to relay the information from one decision maker to another during the design and development phases of engineered systems[14, 15]. Information relayed to decision makers throughout the organization primarily consists of the physics-based and technical characteristics of individual entities within the system. The behaviors based on these characteristics collectively result in behavior that is unique to the entire system. An organization's structure dictates, amongst other operational policies, the systemic manner in which information is passed between decision makers. Of the information present within the organization, that which represents technical characteristics that are passed between subsystems are herein referred to as physics-based couplings. The interfaces that facilitate the transfer of this information within the organization are organization couplings. Challenges that arise from the handling of these two disparate compositions (technical versus organizational) are addressed within this work.

Current approaches to design within systems engineering rely on frameworks that are based on the capturing and relaying of stakeholder preferences throughout the organization by the use of requirements[3, 16-24]. Models such as the V-Model, the Spiral Model and the Waterfall Model

are used for requirements-based systems engineering where the feasibility of a proposed solution defines the measure of success[17]. Feasible systems are identified by their ability to meet stakeholder expectations which are translated into requirements. These requirements-based approaches prescribe the decomposition, dissemination and elicitation of stakeholder requirements from the highest level of the organization to the lowest levels where decision makers can make decisions to satisfy the requirements presented to them. The requirements generated at every level within the system's hierarchy act as representations of preferences at the level immediately above it.

Requirements are managed by the use of documents namely, the Stakeholders' Requirements Document (StkhldrsRD), the System Requirements Document (SRD) and the Systems Requirement Validation Document (SRVD)[17, 25]. The design process then proceeds from the lowest level to the highest integrating the various parts of the system, while making sure the requirements are satisfied at each level throughout the hierarchy. In instances where decisions made based on requirements do not provide feasible outcomes for any requirement, the design process is forced to regress to the formulation of said requirement or parent requirement. A parent requirement in this case is one that was decomposed to form one or more lower level requirements. The regress in the design process results in product delivery delays as well as cost overruns for engineered systems. These effects are inflated when dealing with LSCESs due to the characteristics of these systems as discussed earlier and provide an opportunity for improvement. To address the deficiencies of a purely requirements-based systems engineering design process, Value-Driven Design can be incorporated by capturing stakeholder preferences in value functions as opposed to the representation of these preferences as requirements that are imposed on a system.

In so doing, this reduces the dependence of the design process on requirements which can often be inaccurate representations of stakeholder preferences.

Couplings in systems engineering are managed by the use of Interface Control Documents (ICDs)[25]. When considering LSCESs, there are a number of challenges that arise when dealing with these systems' couplings. One significant challenge that arises from the number of couplings associated with any given decomposed LSCES is the management of these couplings. These couplings demand large ICDs to manage not only the number but also the nature of couplings corresponding to these systems which makes it increasingly difficult to manage the design process. In addition to the large ICDs, this approach to couplings does not provide measurable impact on the system due to changes that are related to couplings.

The understanding of the relationship between couplings is used to improve the predictive modeling for the design, development, operation and retirement of LSCESs. By doing so, the author proposes the possibility of increased accuracy in LSCES modeling thereby allowing for improved decision making. This is accomplished by the inclusion of Multidisciplinary Design Optimization which is a field that enables system optimization while addressing couplings during both system analysis and optimization.

Aside from the complexity of predictive modeling that is a result of both physics-based couplings and organizational couplings, the presence of uncertainty increases the challenges associated with LSCES design and development. Just as physics-based characteristics have uncertainty about them, organizations have uncertainties that correspond to various aspects of the organizations which include decision makers and their biases. This human factor results in uncertain outcomes when measuring organization structures by their policies and infrastructure set

in place to facilitate the design. As with the analysis of LSCESs and the uncertainty of physics-based characteristics, the author will explore the impact of uncertainty within organization structures and the impact they have in the analysis of complex systems.

The research presented here by the author is to address the deficiencies present in the current systems engineering requirements-based design process. This is to be accomplished by bringing together Organization Design (OD) with a combination of Multidisciplinary Design Optimization (MDO) and Value-Driven Design (VDD) to compliment research previously performed on the improvement of systems engineering.

Research Objectives

It is the aim of the author to accomplish the following research objectives in conducting the presented research work.

Research Objective 1: Develop a method to quantitatively capture organization structure characteristics in the value modeling of LSCESs.

The current modeling of engineered systems and in particular LSCESs does not take into account the role of organization structures in quantitative evaluation of final system's design evaluation. It is well known that the organizational structure significantly influences the outcome of the design enterprise. The question that follows is to be answered by the research to accomplish objective 1. "Will use of Organization Design and VDD in an MDO framework allow for improved evaluation of complex systems design with regard to desired value by improving the fidelity of models that are generated?" This will be addressed by the development of a value function that captures attributes associated with organizational structures of LSCESs.

Research Objective 2: Develop a method to quantitatively capture organization structure uncertainty in the value modeling of LSCESs.

Uncertainties in communication in an organization exist just as they do for a system's physics. The nature of human communication affects the outcome of LSCESs as information is relayed in different ways and from different people. Uncertainty in this communication of information needs to be captured to accurately model the LSCES and develop alternatives and a final design. To address this, there needs to be an incorporation of uncertainty in the value function specifically pertaining to human communication.

Research Objective 3: Develop a method to quantitatively capture decision maker perception of system information within an organization structure due to uncertainty in the value modeling of LSCESs.

Belief systems within organizations differ amongst decision makers. It is therefore inaccurate to assume that developing a value function to accurately represent stakeholders' preferences will result in the development of an LSCES that is consistent with these preferences without taking into account the variation in decision makers' beliefs of system information that is subject to uncertainty. There is a need to take into account varying decision maker beliefs and address them in the decision making at every level throughout the hierarchy. The accomplishment of this objective will provide improved LSCES predictive modeling and thereby enable improved decision making.

Organization of Dissertation

The work presented here will proceed with the necessary background to the research which is presented in Chapter 2. The section to follow (Chapter 3) will be the definition of the

demonstrative complex system that is used to capture characteristics of complex systems as well as demonstrate the methodology used to capture organization structure attributes in the value functions for complex systems. Chapter 4 will focus on describing the satellite system that is used as a test system to demonstrate the effects of capturing organization structure attributes of LSCESs. Chapter 6 will focus on a deterministic design methodology to capture organization structure attributes in the value functions of LSCESs. It will begin with a description of the organization structure attributes and the associated value function formulation. It will conclude with the application of the value function to the sample complex system and the satellite system as demonstrations of the concept. Chapter 7 will focus on stochastic design of complex engineered systems where uncertainty is associated with the organization structure of complex systems, particularly LSCESs. The chapter will begin with the description of the sources of uncertainty within the organization and then identify how the uncertainty is characterized and captured in system evaluation. Chapter 8 will include a methodology to capture the variation in beliefs of decision makers within an organization and how that affects the value of an LSCES during design. The last chapter (Chapter 9) of this body of work will present a summary of the research conducted by the author, conclusions based on the findings and future work inspired by the work herein.

CHAPTER 2: BACKGROUND

Multidisciplinary Design Optimization

Multidisciplinary Design Optimization (MDO) is an approach to design optimization whose development began in the 1980s primarily to address complex optimization problems such as those faced with complex systems[26-29]. Initially, the development of MDO focused on bi-level, hierarchical decompositions of systems[26, 27, 30]. This later evolved into a focus on overall system optimization[27, 29]. The frameworks that have been developed in MDO provide the techniques necessary to perform analyses of subsystems when designing LSCESs thereby allowing for the regulation of system behavior by ensuring the interactions between subsystems are captured and represented throughout the optimization process. This is accomplished by utilizing these frameworks that aid in the capturing of couplings present between subsystems within a complex system. Objective functions used in these frameworks provide the ability to use single or multiple objectives that relate to these engineered systems. Requirements imposed on systems are captured as constraints to which the objective function is subject. These frameworks include All-At-Once (AAO), Individual Design Feasible (IDF), Simultaneous Analysis and Design (SAND) and Multidisciplinary Feasible (MDF)[31-35]. IDF and MDF can further be broken down based on specific applications of these frameworks as is presented in[36]. Of the developed frameworks that have been mentioned, MDF is used in this work in the research conducted to accomplish the stated objectives. MDF allows for a system analysis to be conducted during all iterations of an optimization sequence. This is particularly beneficial as it provides a consistent behavior variable set with respect to the design variable set for every system analysis thereby providing information that accurately represents the systems potential throughout the optimization process by capturing the couplings.

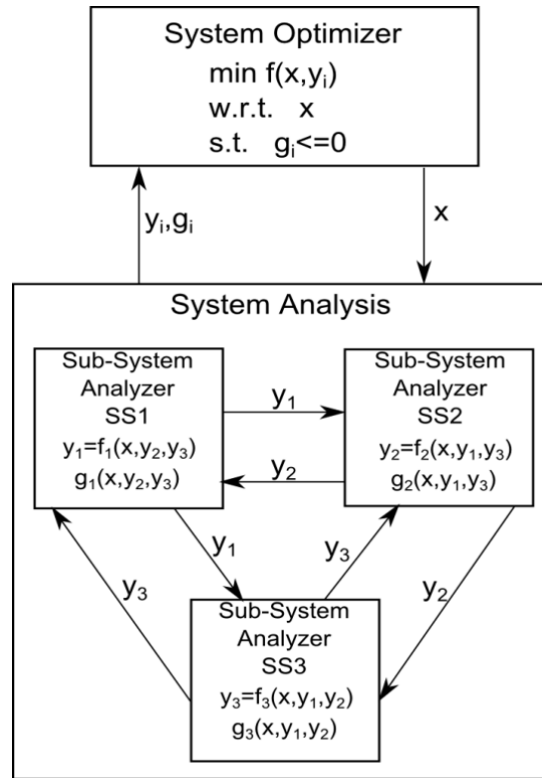

Figure 2.1: An MDF formulation of a complex system for optimization

Fig. 2.1 is an illustration of an MDF representation of a complex system that is made up of three subsystems whose collective outputs characterize the behavior of the entire system. A mainstay of MDO is its provision for the identification, quantification and utilization of couplings that are formed during the decomposition of a complex system. Fig. 2.2 provides an example of a fully coupled system which is made up of two subsystems. The X s represent design variables in the system; the Y s are behavior variables that are outputs from one subsystem and inputs to another. Research work conducted in the past has focused on physics-based couplings present in engineered systems as a result of decomposition of those systems, and how coupling information can be used to improve the design process for complex system[30, 37-39].

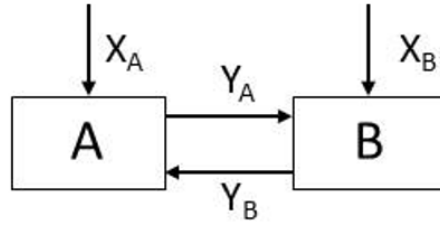

Figure 2.2: A Representation of Two Coupled Subsystems A and B

The quantification of couplings in complex systems is made possible in MDO by the use of the Global Sensitivity Equation (GSE) as demonstrated in Fig. 2.3[35, 40]. These coupling quantifications referred to as coupling strengths are calculated by the solving of the GSE where local sensitivities are calculated and used to determine the global sensitivities thereby providing the ability to predict changes in system behavior due to changes in system characteristics. Researchers have used the quantification of coupling strengths to demonstrate improved efficiency in the design process via coupling suspension and sequencing[33, 35, 38, 39, 41-43].

$$\begin{bmatrix} \mathbf{I} & -\frac{\partial \mathbf{Y}_A}{\partial \mathbf{Y}_B} \\ -\frac{\partial \mathbf{Y}_B}{\partial \mathbf{Y}_A} & \mathbf{I} \end{bmatrix} \begin{bmatrix} \frac{d\mathbf{Y}_A}{d\mathbf{X}_A} & \frac{d\mathbf{Y}_A}{d\mathbf{X}_B} \\ \frac{d\mathbf{Y}_B}{d\mathbf{X}_A} & \frac{d\mathbf{Y}_B}{d\mathbf{X}_B} \end{bmatrix} = \begin{bmatrix} \frac{\partial \mathbf{Y}_A}{\partial \mathbf{X}_A} & 0 \\ 0 & \frac{\partial \mathbf{Y}_B}{\partial \mathbf{X}_B} \end{bmatrix}$$

Figure 2.3: Global Sensitivity Equation for the Coupled System Presented in Fig. 2.2

In the representation of complex systems within MDO, Design Structure Matrices (DSMs) are developed for each system to represent the complexity associated with the decomposition of these systems. DSMs are used to represent various types of system decompositions which include component-based (product) DSMs, people-based (organization) DSMs, activity-based (process) DSMs, and parameter-based (low-level process) DSMs. Physics-based couplings that are present in complex systems are represented by the use of physics-based DSMs while organizational

couplings are represented by the use of people-based DSMs[35, 44-48]. With these DSMs, it is not only possible to show the information that needs to be passed throughout an organization, but also how information is actually passed throughout an organization based on the type of organization structure to which the design structure is subject. These DSMs do not give any insight into the best means to develop LSCESs by virtue of their organization structures. In the same way that alternative designs are evaluated to identify the most suitable solution to a problem statement, the author is interested in identifying the most desirable organization structures to develop respective LSCESs.

Value-Driven Design

Value-Driven Design (VDD) was developed to aid in the understanding of stakeholder preferences, thereby allowing for stakeholder value to directly impact the outcome of systems that are designed by encoding the preferences as measurable values that are relatable to the physics-based characteristics of LSCESs[7, 49-56]. When VDD is applied to the implementation of MDO, the objective function used during the optimization is replaced with a value function that is formulated to relate the physics-based characteristics to the desired preferences with regard to the system[7, 52, 57-62]. By so doing, this presents an alternative to requirements-based Systems Engineering (SE) models for the design of engineered systems. These requirements-based models such as V-Model, Waterfall model and Spiral model involve the reception of requirements by a systems engineer from a stakeholder. These requirements are then used to generate more requirements that are needed at lower levels in the organization. The entire process then involves the formulation and dissemination of requirements down an organization followed by the integration of the system by design choices that satisfy all the requirements that were developed[1, 6, 7, 24, 62, 63]. This approach to design creates two regions of a design space, the feasible region

that satisfies the requirements and the infeasible region that violates at least one requirement. There is no means provided by traditional methods to mathematically identify a superior design in the feasible space. VDD provides a means to capture true stakeholder preferences, e.g. profit, thereby allowing for comparison of alternatives throughout the design space[64-66]. Fig. 2.4 is an illustration of VDD as it would be applied to the design of LSCESs.

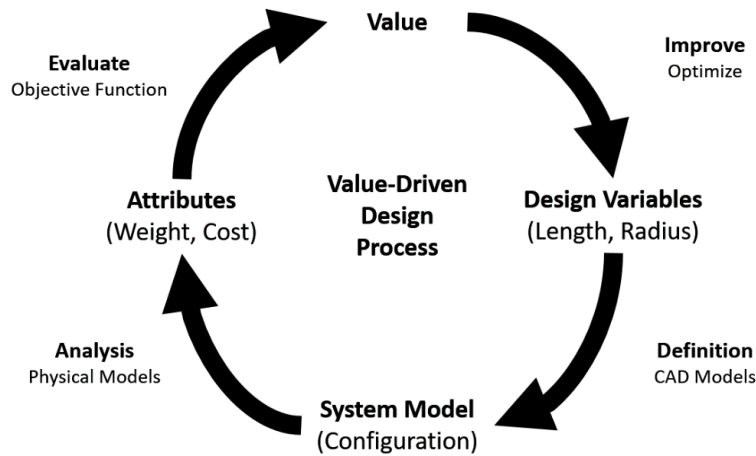

Figure 2.4: A VDD Approach to the Design of LSCESs

VDD provides for a shift from the traditional approach to Systems Engineering (SE) that utilizes frameworks that are requirements-based to one that is value-based. Past research focused on the unifying of VDD and MDO to improve the design process. In this work, the author presents the incorporation of Organization Design (OD) in the formulation of value functions by the inclusion of both product (physics-based) and process (organization) characteristics of the system to improve the design process of LSCES.

Organization Design

Organization Design (OD) is a science that deals with, amongst other phenomena, the formulation of organization structures, used by organizations to coordinate and execute tasks and develop products and services[11, 67, 68]. The design of organizations involves the analysis of structures that characterize the interactions of organization entities. There are five basic parts to an organization: the strategic apex, the techno-structure, the middle line, the support staff and the operating core[10, 69]. All entities within an organization lie in at least one of these five parts. Fig. 2.5 illustrates the basic structure of an organization as aforementioned.

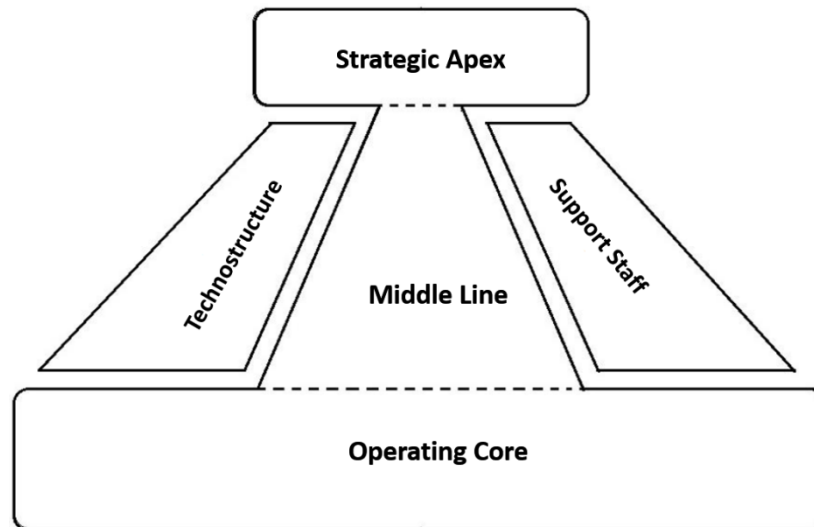

Figure 2.5: Primary Organization Breakdown

The techno-structure and support-staff make up the parts of an organization that influence day to day operations but do not directly affect the output of an organization. An example would be the human resources and accounting that are part of the techno-structure of an organization that manufactures jet propulsion engines. Catering and janitorial staff would fall under the support staff in the aforementioned example. This work focuses on the entities (individuals or teams) that directly affect an organization's output. These are found within the strategic apex, the middle line,

and the operating core. OD facilitates the evaluations of resource utilization which includes parameters and variables such as direction of information flow, task coordination, task specialization, seniority and power. The combination of these factors helps determine where in an origination structure an entity exists or should exist. For example, entities whose primary tasks are specialization specific are found primarily in the operating core (low-level decision makers) while those whose tasks are primarily coordination specific are found within the middle line and strategic apex (higher level decision makers)[67, 70]. In LSCESs, decision makers at every level in an organization can consist of either individuals or teams. The predetermined coordination and interaction of these various decision makers in an organization give the organization its structure. Organizational structures fall into two broad groups; hierarchical structures and decentralized (spider-web) structures. Research has found that sufficiently large organizations whose outputs are predefined products have utilized organization structures that fall under hierarchical structures[9, 14]. Spider-web structures are utilized by organizations that are in an early stage of their development where the company's communication infrastructure is not subject to a formal set of operating procedures. Given LSCESs are produced by large organizations, the hierarchical structures shall be the base structure by which other organization structures will be subject to comparison within this research work.

Fig. 2.6 illustrates a hierarchical organization structure where subsystems are organized into levels and information is passed between levels along predefined channels. An example of this is a level 3 subsystem sharing information with a level 2 subsystem directly above it (which then acts as the coordinator of that information passed up) and a number of level 4 subsystems below it (for which the level 3 subsystem acts as the coordinator of information passed up from the level 4 subsystems). It should be noted that in this case, each subsystem performs coordination

tasks for subsystems at lower levels. Therefore, to pass information from one subsystem to another in the same level, a higher level coordinator, commonly referred to as a manager, needs to be present or involved. The organization connections that allow for the passing of information between entities are the information pathways. The information pathways discussed herein represent the team-based couplings in a system's decomposition.

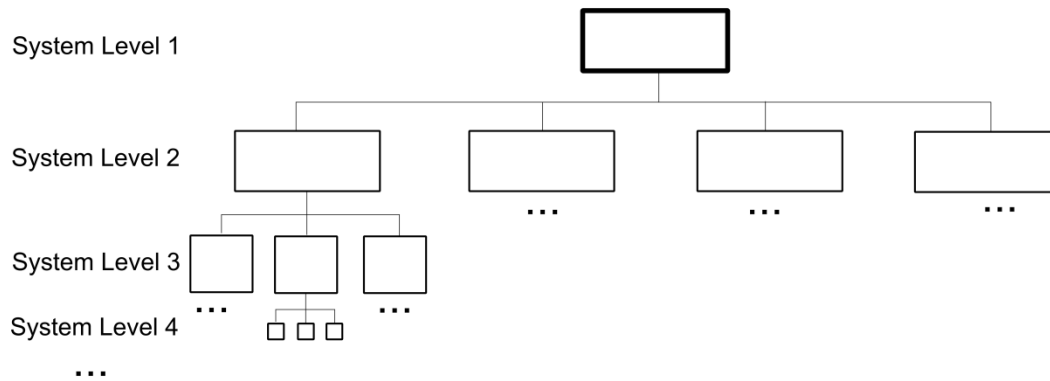

Figure 2.6: Basic Hierarchical Organization Structure

Fig. 2.7 shows a basic hierarchy that demonstrates an information pathway within a level in an organization as well as information pathways between two levels. The bold line that connects subsystem A and subsystem B is the lateral pathway. The bold line that connects the CEO subsystem to subsystem C is a cross level (vertical) information pathway.

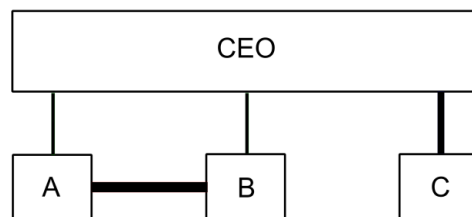

Figure 2.7: Basic Organization Structure Showing Both Vertical and Lateral Couplings

Altering the flow of information in an organization effectively alters the active organization structure. This does not represent a change in the product structures. Product structures in this work refer to the decomposition of a system in terms of information flow that is necessary for the development of a given system. These are visually represented most commonly by Design Structure Matrices (DSMs). Work in OD has shown a strong correlation in organization structures and their product structures[14, 71-73]. This relationship is referred to as ‘the mirroring hypotheses’. Research conducted concludes that tightly coupled organizations will develop products whose structure mirrors that of the organization[68, 74-77]. Additionally, the research also demonstrated that companies have efficient use of resources when their organization structures mirror their product structures. This means an engineered system’s physical structure is exactly the same as its organization structure. For the systems presented in the following sections of the paper, the hierarchical decomposition of the systems are exactly the same as their organization structures. This is a result of rules set in place for operation within the organization that are then projected onto the process to be followed during development of products.

Research work in MDO has investigated the role of decomposition and physics-based couplings to understand how to improve the design and development process for LSCESs[26, 27, 43, 78]. Information gained in this field has led to the use of coupling information of a system to improve design efficiency through coupling suspension[35, 39, 43]. VDD has led to a more accurate means to capture stakeholder preference by enabling designers to assign value to a design. Further work has brought MDO and VDD together to provide an improved design process for LSCESs. This research aims at evolving the design of LSCESs by including organization design in the definition of a system allowing for both product and process to be a part of the evaluation of a system. OD on its own does not provide a means to relate the value of a system to the structure

that facilitates the design of the system in question. The author investigates the formulation of a value function to include not only system attributes, but also organizational structure attributes to define LSCESs. In this manner, it is anticipated that the impact of both design product and process variables can be examined in relation to value. This would lead to an improvement of predictive modeling thus provide increased information that is useful in the decision making process.

CHAPTER 3: COMPLEX SYSTEM

The investigation of an improved systems engineering process in this work is first conducted on a sample complex system. This system is a simplified example of a complex engineered system. It is the goal of the author to use this example system to demonstrate the application where the system maintains characteristics of complex engineered systems while being a small enough scale to allow for traceability of behavior throughout the system from the lowest level to the value function. Fig. 3.1 is an illustration of the complex system that is used to demonstrate the application of the addition of organization attributes to a system value function.

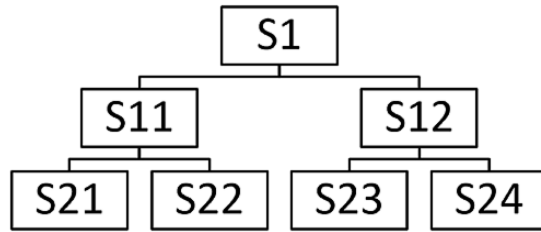

Figure 3.1: Sample Complex System Decomposition

$$V = 2A_{1,1,1} + A_{1,2,1} \quad (3.1)$$

$$A_{1,1,1} = 2A_{2,1,1} + A_{2,2,1} - A_{2,4,1} - 2x_2 \quad (3.2)$$

$$A_{1,2,1} = 3A_{2,3,1} + 2A_{2,4,1} - x_4 \quad (3.3)$$

$$A_{2,1,1} = x_1 - 2x_3 + x_1^2 + A_{2,2,1} \quad (3.4)$$

$$A_{2,2,1} = x_2^2 + \frac{A_{2,1,1}}{2} \quad (3.5)$$

$$A_{2,3,1} = x_3x_4 - 3x_3 - \frac{A_{2,4,1}}{2} + 5A_{2,1,1} \quad (3.6)$$

$$A_{2,4,1} = x_4 - x_6 + x_5^2 + A_{2,3,1} \quad (3.7)$$

In this system, the X's (X_1, X_2, \dots) are the system design variables. These are the variables that can be altered by decision makers to change the behavior of the system. Examples of these include the chord of an airfoil section on an aircraft, the diameter of the cylinder on a reciprocating engine and, the length, width or diameter of a fuel tank. The A's, expressed as $A_{a,b,c}$, in the system are subsystem outputs. They represent inputs to other systems (behavior variables) as well as system attributes (characteristics). The subscript, 'a', denotes the subsystem level in the system, 'b' denotes the subsystem within a given subsystem level, and 'c' denotes the attribute number within a subsystem. An example of a behavior variable is the capacity of a fuel tank in terms of volume. This information can be used by a different entity in the system to obtain information on the range of a vehicle if the fuel consumption at cruising speed is available. This information can also be used to determine a system attribute such as the cost to manufacture a fuel tank based on the volume of material used for the fuel tank mention above. V in the system is the highest level output that is obtained from the value function. As such, it gives the value associated with the physics-based system calculated. The system contains a number of traits associated with complex systems such as full coupling which is present between subsystems S21 and S22 as well as between S23 and S24. The coupling between S21 and S22 is a direct result of the outputs of each subsystem serving as the inputs of the alternate system. Specifically, in Eq. 3.4, the value of $A_{2,2,1}$ is required to calculate the value of $A_{2,1,1}$ in addition to the design variables x_1 and x_3 . $A_{2,2,1}, x_1$ and x_3 serve as the design variables that are necessary to calculate the behavior variable $A_{2,1,1}$. In Eq. 3.5, the value of $A_{2,1,1}$ is required to calculate the value of $A_{2,2,1}$ in addition to design variable x_2 . $A_{2,1,1}$ and x_2

serve as the design variables required to calculate the behavior variable $A_{2,2,1}$. As a result of each behavior variable in one sub system being a design variable to the coupled subsystem, there is a need for iteration until consistency is achieved. The two subsystems are determined to be consistent when the behavior variable inputs as design variables no longer result in a change in behavior variable values for every iteration. The behavior variables $A_{2,3,1}$ and $A_{2,4,1}$, associated with subsystems S23 and S24, have a similar relationship due to coupling thus require iteration to attain consistency. A more detailed discussion on the relationship between design variables, behavior variables, attributes and value can be found in [64, 65].

The system presented above can be represented by use of a Design Structure Matrix such as is presented in Fig. 3.2. The DSM used to represent the system in terms of subsystems, design

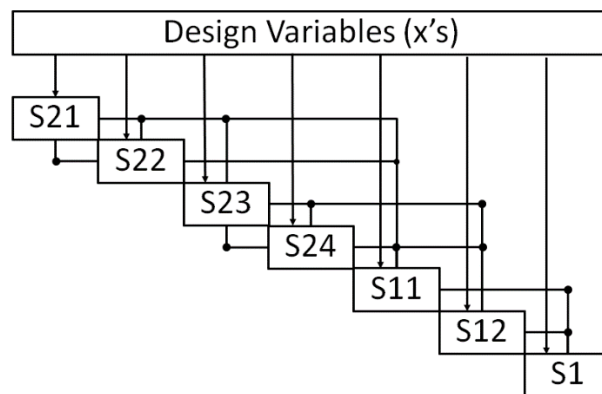

Figure 3.2: A Complex System's Component-Based DSM

variables and behavior variables is a component based DSM. In this representation, inputs to subsystems are represented by lines connected to the horizontal edges of the rectangles representing subsystems. Outputs are represented by lines connected to the vertical edges of the subsystem rectangles. The lines that leave the right edge of each box that represents a subsystem are referred to as feed forwards. They are the behavior variables in the system which represent the

subsystem outputs. The lines that leave the left edge of subsystems are feedbacks which are also behavior variables. A subsystem that has behavior variables that are represented by lines leaving both the left and right edges represent subsystems that are fully coupled with another system. Fully coupled subsystems can also be identified as those with lines on the lower edge that represent input from a feedback.

To demonstrate the effect of organization structures on systems, the author utilizes two aspects of organization structures, task execution and information links where organization structures are an integral part of OD. There are two types of tasks that can be performed by any given entity in the organization namely, coordination tasks and specialization tasks. Specialization tasks are any effort that produces information that is unique to a specific decision maker or decision making team. Coordination tasks are any effort that results in the propagation of information from one decision maker to another within an organization. These tasks are further broken down into the cost associated with each task as well as the time taken to execute the tasks. The information links on the other hand prescribe the authorized communication between entities in the organization thereby characterizing the organization's structure.

Following this description of the system used to demonstrate complexity, Chapter 4 discusses the system that represents a large-scale complex engineered system.

CHAPTER 4: SATELLITE SYSTEM

A geo-stationary commercial communication satellite is used as the example of an LSCES upon which research on improved system engineering design approaches are conducted. The satellite system used in this work is based on approximations and estimations based on past data as well as assumptions based on extrapolation and substitution of knowledge[61, 64-66]. This LSCES is a composition that is made up of a communication satellite, a set of ground stations and a launch vehicle that is required to get the satellite into orbit. Fig. 4.1 is an illustration of a commercial communication satellite, a ground antenna that represents ground stations and a launch vehicle.

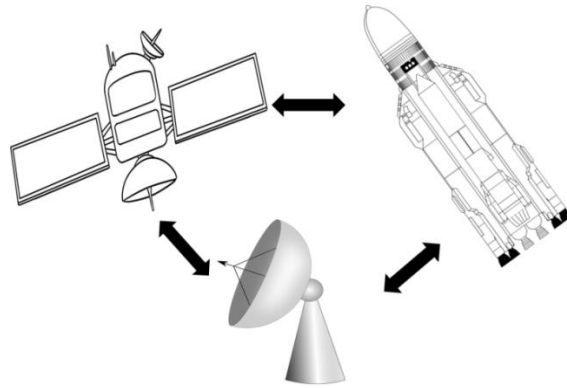

Figure 4.1: Communication Satellite System Consisting of Ground Station, Launch Vehicle and Satellite

The role of a communication satellite is to serve as a transmission relay. This is accomplished by the reception of signals from ground transmitting stations, followed by the amplification and processing of the received signals and finally, the transmission of the processed signals to ground receiving stations. The satellite's bus contains the subsystems that facilitate the accomplishment of signal transmission. The satellite system is defined by thirty six (36) design

variables. The variables are a combination of discrete (22) and continuous (14) design variables. This system is hierarchically decomposed into three (3) subsystem levels as shown in Fig. 4.2.

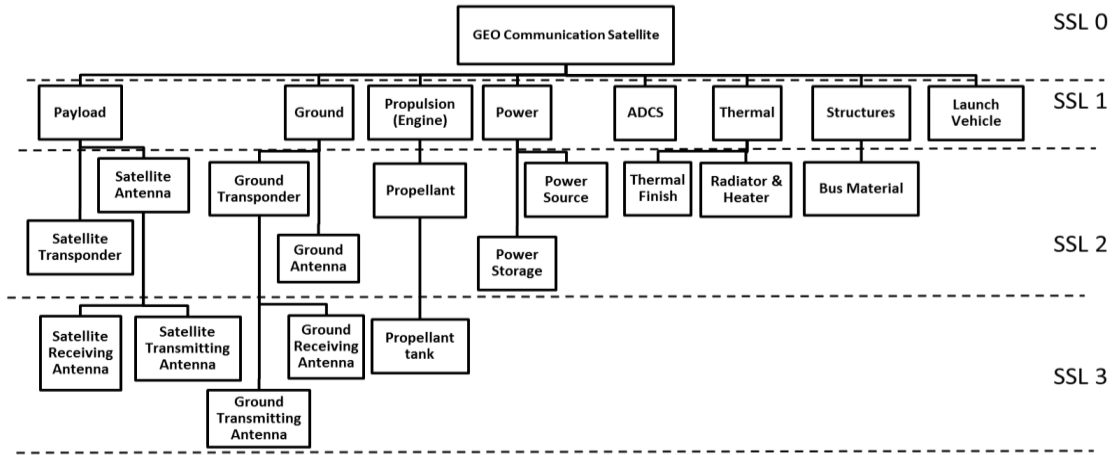

Figure 4.2: Hierarchical Decomposition of a Communication Satellite System

The equations that are used to represent the attributes and behavior variables that are functions of design variables in the subsystems are presented in Appendix A as developed for a similar application by Dr. Kannan[61]. Fig. 4.3 represents the DSM of the first subsystem level of the satellite system. The subsystems represented in the DSM contain within them other subsystems that are illustrated in the 2nd and 3rd subsystem level such as are present in Fig. 4.2.

Chapter 6 involves the methodology and application of methodology and results associated with the incorporation of organization design attributes in the value models of the complex systems presented in Chapter 3 and Chapter 4.

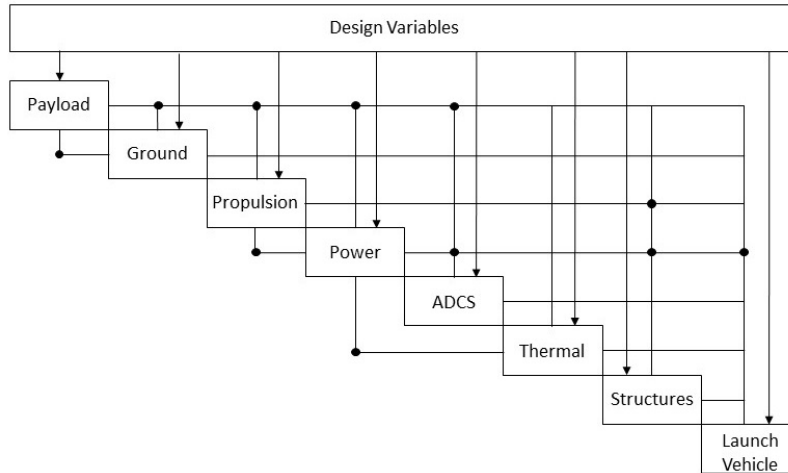

Figure 4.3: Attribute-Based DSM of Satellite System

CHAPTER 5: PRELIMINARY SATELLITE SYSTEM STUDY

As an initial investigation into the need to incorporate Organization Design in the value modeling of complex systems and by extension, LSCESs, the author conducted a preliminary study to determine the plausibility of representing organization parameters in system value functions. This chapter details the process of this preliminary study and its results. The author shall demonstrate the need to capture organization structures and organizational parameters in value function modeling for LSCESs. This will lead to Chapter 6 which provides the formal approach that the author proposes be adopted in the design and development of LSCESs.

Organization Structure Parameters

Organization structures are characterized by the information pathways in the structure, the time associated with execution of tasks by subsystems, the time taken to relay specific information, the cost incurred by execution of tasks, the direction of the flow of information, and the balance to be attained between task coordination and task specialization by each individual or team. This chapter focuses on the effects of organization structure change on the satellite system value, where the structural change results in changes in information paths.

To include the organization structure in the value function, a number of assumptions are made on the system. First, all individuals in the organization that are working on designing the system fall into one of the subsystems presented in the hierarchy presented in Chapter 4. An individual person can be a decision maker or a number of people can collectively be a single decision maker. The subsystems present in the organization are made up of teams of decision makers. In particular, a decision maker is responsible for providing information on a behavior variable or attribute. The subsystems present in the satellite system therefore also represent decision making teams with multiple decision makers corresponding to behavior variables and/or

attributes in the organization structure. This satellite system has twenty nine (29) decision makers that correspond to the number of functions that provide attribute and behavior variable information. A change in one or more decision makers therefore results in a change in the organization structure.

To allow for evaluation of the satellite system, which includes the organization structure, a value function was established to account for the decision makers in the organization. This was done by attributing cost of function evaluation to each decision maker. For example, a fluids group would have some cost associated with running a CFD analysis originating from such costs as labor, computation time, and overhead. The total cost of the number of function evaluations for each decision maker was added to system's total cost. Net present profit, the value function for this satellite system [65], was previously calculated as shown in Eq. 5.1. The new value function for the system which incorporates the cost of function evaluation is shown in Eq. 5.4 in which the net present profit of the satellite system is a function of the total cost of the satellite system and the revenue generated. The total cost is a function of the communication satellite cost and the design process (organization) cost. The organization cost as shown in Eq. 5.2 is calculated by taking into account the cost of executing a function, the number of times a function is executed in a single analysis cycle and the number of iterations performed in the analysis.

$$V = f(\text{Satellite Cost}, \text{Revenue}) = -\text{Satellite Cost} + \sum_{y=1}^{OL} \frac{\text{Revenue}_y}{(1 + r_d)^y} \quad (5.1)$$

r_d : discount factor = 10%

OL : Operational Lifetime = 10 years

y : year

$$\text{Org Structure Cost} = \text{iter} * \sum_{n=1}^s n_f * f_cost_n \quad (5.2)$$

f_cost_n : cost of function execution of index n

s : total number of functions = 29

n_f : number of function executions

n : system function index

$iter$: number of iterations in the analysis

$$\text{Total Cost} = \text{Satellite Cost} + \text{Org Structure Cost} \quad (5.3)$$

$$V = f(\text{Total Cost}, \text{Revenue}) = -\text{Total Cost} + \sum_{y=1}^{OL} \frac{\text{Revenue}_y}{(1 + r_d)^y} \quad (5.4)$$

r_d : discount factor = 10%

OL : Operational Lifetime = 10 years

y : year

Change in Organization Structure

There are several characteristics that define a unique organization structure. Altering any one of these characteristics effectively alters the organization structure of a system. In this chapter, the author investigates how the change in organization structure that is caused by a change in information flow within an organization. There are several situations that could lead to disruption of information in an organization including the absence of a decision maker due illness or vacation. A team of decision makers may also be absent if, for example, employees are on strike. Another potential situation is interruption of a supply chain that would prevent a team from executing its tasks given lack of materials to do so. In such situations, their decision to halt progress or proceed

without certain information is faced. In a case where the decision to proceed is selected, there is need to fill the gap created by lack of information. Prior knowledge and past experience become the information to base decisions off of in these cases.

The datum for this study is an organizational structure that mirrors the system hierarchy that was presented earlier Fig. 4.2. This allows for the simplification of the analysis by excluding the cost of information flow throughout an organization. Any changes to the decision makers in the system will alter the structure giving a non-mirroring organization structure. Calculating the system value for a non-mirrored structure gives a value to be compared to that of the mirrored structure. The value of the system is calculated, resulting in the impact of the change in organization structure. The datum is determined by selecting design variables that define the physical part of the satellite system for deterministic design. A set of costs that are associated with respective function executions is also established. The set of design variables and function costs are then used throughout the study. This is to say that only the organization structure changes and not the set of the design variables that characterize the physical part of the satellite system. In the case of uncertain design, a probability distribution is applied on the design variables. An analysis is performed on the system to obtain the respective value (Net Present Profit) of the design with an organization that mirrors the physical decomposition. Studies on changes in the organization are then performed comparing the results to this baseline. The following sections present the various test cases performed in this study.

Deterministic Design

For deterministic design (design without physics-based uncertainty), a number of studies were conducted where change in organization structure was due to information disruption. The first set of studies involved the removal of a decision maker followed by the removal of a team of

decision makers which results in altering the organization structure from a mirrored structure to non-mirrored structures. To generate non-mirrored structures by altering an individual decision maker, the sensitivities of attributes to system value were calculated for subsystem level two attributes. This was done to enable the selection of attributes that had varying impacts on the value function of the system. It should be noted that there is potential information to be gained from relating the coupling strengths to the value effects of structural changes at the corresponding decision maker's location in the organization. This is addressed in the discussion of results. Table 5.1 shows the results of the sensitivities calculations. Following this information, attributes with varying sensitivities to the system value are selected. This study uses battery mass, mass of transponders, array size, and mass of propellant.

For the first scenario, the decision maker providing information on battery mass is presumed absent (case 1.a.i-iii). This demands the use of prior knowledge to facilitate the analysis of the system to obtain the net present profit. The prior battery mass is given for three different cases and used in analyses. The system value for the analysis is then used to calculate a potential change in value with regard to the datum net present profit for each initial battery mass case. Next, the decision maker that is absent is responsible for providing the mass of transponders. An analysis is run to obtain the net present profit for the system. The difference between this and the datum net present profit is calculated. The above scenarios are run for the mass of transponders decision maker's absence (case 1.b.i-iii), the array size decision maker's absence (case 1.c.i-iii) and the mass of propellant decision maker's absence (case 1.d.i-iii).

Table 5.3: Subsystem level 2 normalized attribute sensitivities

Subsystem Level 2 Attributes	Normalized Global Attribute Sensitivities
Mass of transponders	-0.0043
Power to payload	-0.0093
Volume of transponders	0.0000
Cost of satellite antennae	-0.0007
Cost of ground transponders	0.0000
Cost of ground transmission antenna	-0.0001
Cost of ground receiving antenna	-0.0009
Cost of solar array	-0.0119
Array size	-0.0376
Battery mass	-0.0127
Battery capacity	-0.0135
Mass of propellant	-0.0400
Cost of Engine	-0.0010
Cost of thermal finish	0.0000
Power for thermal	-0.0022
Cost of bus per kg	0.0000

The second set of case studies involves the absence of a team of decision makers. Particularly, multiple decision makers are absent in the organization. A team in this case means that the absent decision makers are all in the same subsystem as opposed to a number of decision makers being absent from different areas in the organization. Teams considered are those teams in subsystem level 2 and subsystem level 3 of the organization structure. Power source (solar array), ground receiving antennae, and propellant tank are the teams selected for this study.

To begin, a set of initial attribute values corresponding to the power source team is selected (case 2.a.i, ii). This is the information that is used to replace the absent team. An analysis is then performed to obtain the system's net present profit. This is repeated with a different set of values

for the power source attributes and behavior variables. The second case involves selecting a set of attributes to represent a missing ground receiving antennae team (case 2.b.i.ii). Two analyses are performed; each with a different set of attribute values associated with the ground receiving antennae team. Net present profit for the system in each case is determined in this way. The final case study on the organization's structural change on the deterministic system is the replacement of the propellant tank team (case 2.c.i, ii). Two scenarios are analyzed for this team in the same way the power source team and ground receiving antennae team were analyzed.

Stochastic Design

Uncertain design in this chapter refers to the physical uncertainty that is expected when designing LSCESs. In the case of the commercial satellite, the uncertainty in the product is drawn from the continuous design variables. Uncertainty in the design process is not explored in this chapter but is addressed in Chapter 7. To begin the study of the impact of organization design on the satellite system, datum is established as was done in the deterministic cases. This is done by selecting the same design point in the design space as was used in the deterministic studies. A probability distribution is applied on the continuous design variables and the net present profit is calculated. Due to the uncertainty in the physical system, a Monte Carlo simulation of one hundred thousand (100,000) outcomes is generated all using the same design variables and design variable probability distributions. The result is a probability distribution of net present profit values that are associated with a given initial design set. A mean net present profit for the simulation is calculated.

The first case study involves an organization structure that is missing the decision maker responsible for providing battery mass information (case 3.a.i). The same scenario is repeated with a different probability distribution on the battery mass resulting in a different alternative set for the satellite system (case 3.a.ii).

Table 5.2: Case studies performed to test the impact of information disruption

Case studies		
Datum (Deterministic Design, Mirrored Org Structure, Full Information Flow)		
Case 1 – Deterministic Design, Single Decision Maker, Non-Mirrored Structure, Disrupted Information	Case 1.a – Structure with missing battery mass decision maker	Case 1.a.i
		Case 1.a.ii
		Case 1.a.iii
	Case 1.b - Structure with missing mass of transponders decision maker	Case 1.b.i
		Case 1.b.ii
		Case 1.b.iii
	Case 1.c - Structure with missing array size decision maker	Case 1.c.i
		Case 1.c.ii
		Case 1.c.iii
	Case 1.d - Structure with missing mass of propellant decision maker	Case 1.d.i
		Case 1.d.ii
		Case 1.d.iii
Case 2 - Deterministic Design , Team Of Decision Makers, Non-Mirrored Structure, Disrupted Information	Case 2.a - Structure with missing power source team of decision makers	Case 2.a.i
		Case 2.a.ii
	Case 2.b - Structure with missing ground receiving antennae team of decision makers	Case 2.b.i
		Case 2.b.ii
	Case 2.c - Structure with missing propellant team of decision makers	Case 2.c.i
		Case 2.c.ii
Datum (Uncertain Design, Mirrored Org Structure, Full Information Flow)		
Case 3 - Uncertain Design , Non-Mirrored Org Structure, Disrupted Information Flow	Case 3.a - Structure with missing battery mass decision maker	Case 3.a.i
		Case 3.a.ii
	Case 3.b - Structure with missing mass of transponders decision maker	Case 3.b.i
		Case 3.b.ii
	Case 3.c - Structure with missing ground receiving antennae team of decision makers	Case 3.c.i
		Case 3.c.ii

The second case study involves the absence of a decision maker responsible for information on mass of transponders. This absence causes disruption of information that result in an organization structure for the satellite system that does not completely mirror the reference design. Two initial probability distributions are established for the mass of transponders and a Monte Carlo simulation of 100,000 generations is run for each distribution (case 3.b.i, ii). These result in two net present profit probability distributions with respect to the two probability distributions used to simulate the absence of the decision maker responsible for the provision of mass of transponders information. The net present profit means for these are also calculated and presented.

The final study on uncertainty addresses the potential impact of organization structure change due to information disruption that is caused by a team of decision maker's absent. The ground receiving antennae team is used for this case study. In order to determine the impact on the value of the system, information on attributes that are handled by this team of decision makers needs to be represented as a probability distribution (case 3.c.i, ii). This is achieved by establishing two probability distributions as prior information used in analyses. One of the distributions corresponds to the mass of the ground receiving antennae and the other corresponds to the gain of the ground receiving antennae. A second pair of probability distributions is generated, one for each attribute. Two Monte Carlo simulations, each with 100,000 runs, are generated to obtain net present profit probability distributions associated with each set of prior information that was used to simulate the absence of the ground receiving antennae team. Table 5.2 summarizes the case studies that are investigated in this chapter.

Results

Table 5.4: Net present profit values for single decision maker information disruption

Attribute	Attribute Value (Kgs)	Net Present Profit, NPP (\$)	Change in NPP (\$)	% error in NPP
Battery Mass (Datum)	133	150,914,278	0	0.00
Battery Mass (fixed)	100	151,940,724	1,026,446	0.68
Battery Mass (fixed)	200	148,836,731	-2,077,547	-1.38
Battery Mass (fixed)	400	142,633,071	-8,281,207	-5.49
Mass of transponders (Datum)	393	150,914,278	0	0.00
Mass of transponders (fixed)	100	160,493,492	9,579,215	6.35
Mass of transponders (fixed)	200	157,222,813	6,308,536	4.18
Mass of transponders (fixed)	500	147,423,543	-3,490,735	-2.31
Array Size (Datum)	26.2	150,914,278	0	0.00
Array Size (fixed)	15	152,153,555	1,239,278	0.82
Array Size (fixed)	30	150,494,607	-419,671	-0.28
Array Size (fixed)	50	148,283,543	-2,630,735	-1.74
Mass of propellant (Datum)	384.2	150,914,278	0	0.00
Mass of propellant (fixed)	500	148,289,153	-2,625,124	-1.74
Mass of propellant (fixed)	200	155,123,405	4,209,128	2.79
Mass of propellant (fixed)	1000	137,040,656	-13,873,622	-9.19

With reference to Table 5.22, the first case study (case 1.a – 1.d) was on the impact of organization structure change by way of information disruption caused by the absence of a single

decision maker. Presented in Table 5.3 are the results associated with a single decision maker's absence. It is observed that for the attributes chosen, there is a decline in net present profit for information used in non-mirrored structure where the attributes that are smaller than the values obtained in the mirrored structures. For values larger than the datum attribute values, there is a decrease in value associated with prior values that are larger than the datum design attribute values. This because these measures contribute more to the satellite's cost than they do to its revenue at this point in the design space.

The contribution of the attribute to the value function varies depending on the point in question in the design space. This points to the sensitivities presented in Table 5.1 that showed a negative relationship to the net present profit of the system. The difference in net present profit in this case is a result of the error due to the discrepancy in information. In particular, design variables affecting more than one attribute result in false net present profit value where there the design variable does not provide the accurate attribute value. For example, in case study 1.a.ii the battery designer is absent. Due to this absence the rest of the decision makers agree that they will assume that the designer can create a battery that weighs 200 kgs, given the design variables that have already been set. It is known that for that set of design variables the battery mass will be 133 kg. With the absence of the designer the organization determines that the design variable set results in a system with a value off \$148,836,731. This evaluation is \$2,077,547 less than the true system value, resulting in an error of 1.38% associated with the absence of the battery mass designer.

Table 5.4: Net present profit values for team decision maker information disruption

Team	Net Present Profit, NPP (\$)	Total Cost (\$)	Δ in Total cost (\$)	Δ in Org cost (\$)	NPR (\$)	Δ in NPR (\$)	Δ in NPP (\$)	% Δ in NPP
Datum	150,914,278	54,747,367	0	0	205,661,645	0	0	0.00
Power source (Solar Array)	150,192,257	55,469,387	722,020	-1,285,000	205,661,645	0	-722,021	-0.48
Power source (Solar Array)	142,541,032	63,120,612	8,373,245	-1,285,000	205,661,645	0	-8,373,246	-5.87
Ground receiving antennae	117,764,167	54,565,601	-181,766	-170,000	172,329,769	-33,331,876	-33,150,111	-28.15
Ground receiving antennae	167,774,671	54,589,145	-158,222	-170,000	222,363,816	16,702,171	16,860,393	10.05
Propellant Tank	149,138,377	56,523,268	1,775,900	295,000	205,661,645	0	-1,775,900	-1.19
Propellant Tank	151,071,212	54,590,433	-156,934	295,000	205,661,645	0	156,934	0.10

Table 5.5: Mean net present profit values for structure change under uncertainty

Team	Net Present Profit, NPP (\$)	Δ in NPP	% Δ in NPP
Datum	150,923,695	9,417	0.01
Battery Mass	144,629,337	-6,284,941	-4.35
Battery Mass	151,961,589	1,047,311	0.69
Mass of transponders	160,459,939	9,545,661	5.95
Mass of transponders	152,348,646	1,434,368	0.94
Ground Rec. Antennae	117,404,134	-33,510,144	-28.54
Ground Rec. Antennae	167,518,387	16,604,109	9.91

The second case study (case 2.a – 2.c) investigated the absence of a decision making team that resulted in non-mirroring structures. Table 5.4 shows the results of case 2. There is a vast difference in the observed data that points to a number of possibilities. When looking at the power

source team's absence, there is a small change in net present profit. Both samples produced a reduction in net present profit value. This may alludes to the entire team having a positive contribution to the value function. The Ground receiving antennae team's samples resulted in large percentage changes in value (\$-33,150,111 and \$16,860,393). These were the largest observed in the deterministic studies alluding to a team whose overall sensitivity to the value function is considerably higher than the teams and individuals sampled. For case 2.b.i, the change in net present profit is primarily due to the change in net present revenue (\$-33,331,876). Organization cost reduces for the Ground receiving antennae team test cases (case 2.b.i, ii) due to reduced cost from not having to perform tasks related with this team. However, for case 2.a.i-ii and case 2.c.i-ii, the organization cost increases. Increase in cost in these instances can be attributed to the need for additional iterations to determine the satellite's net present profit given the discrepancy between design variables and the attribute values corresponding to the altered decision making teams. The propellant tank team's changes in value were significantly lower on either side of the datum net present profit. Of the three teams used to alter the structure of the organization, the ground receiving antennae is the only team that contributes to the net present revenue and thus has the largest percentage change in net present profit despite having the smallest change in the organization cost of the three teams. The ground receiving antennae team has the smallest change in total cost yet the largest change in net present profit for the satellite system. This points to a higher sensitivity to the system value at this point on the design space. Tests conducted showed a change in organization cost for each cases 2.a – 2.c confirming that it is possible to capture the design process in the definition and evaluation of the satellite system. There is thus potential for a greater role of the organization structure in the definition of the system if more organization traits are represented in the value function.

Uncertainty in design was also considered when conducting the studies on the impact of disruption of information flow in a satellite system's organization structure. Of the individual decision maker test cases under uncertainty, both the battery mass structural alteration (See Fig. 5.1a, Fig. 5.1b) and the mass of transponders alteration (See Fig. 5.1c, 5.1d) have differences in net present profit values that are the same scale as those for deterministic design. Results on the ground receiving antennae team (See Fig. 5.1e, Fig. 5.1f) show the largest change in net present profit of the satellite system.

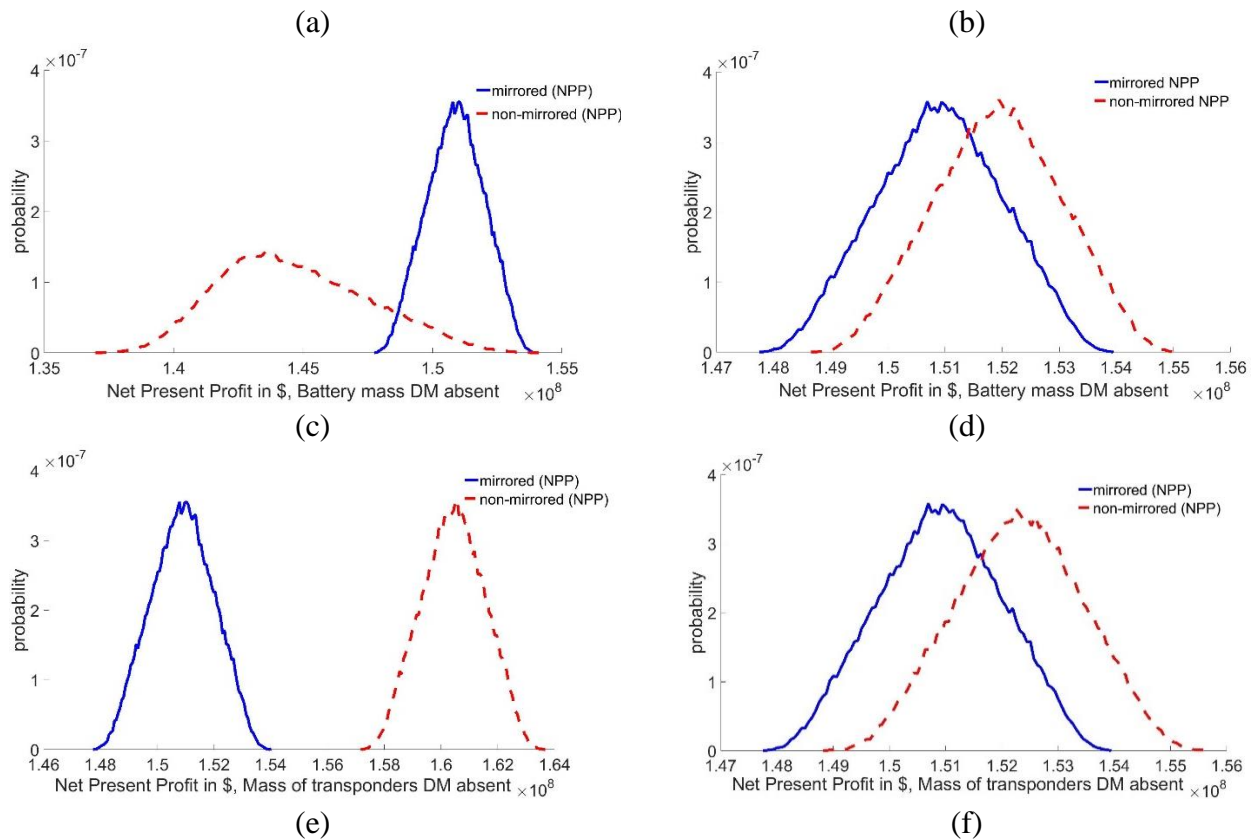

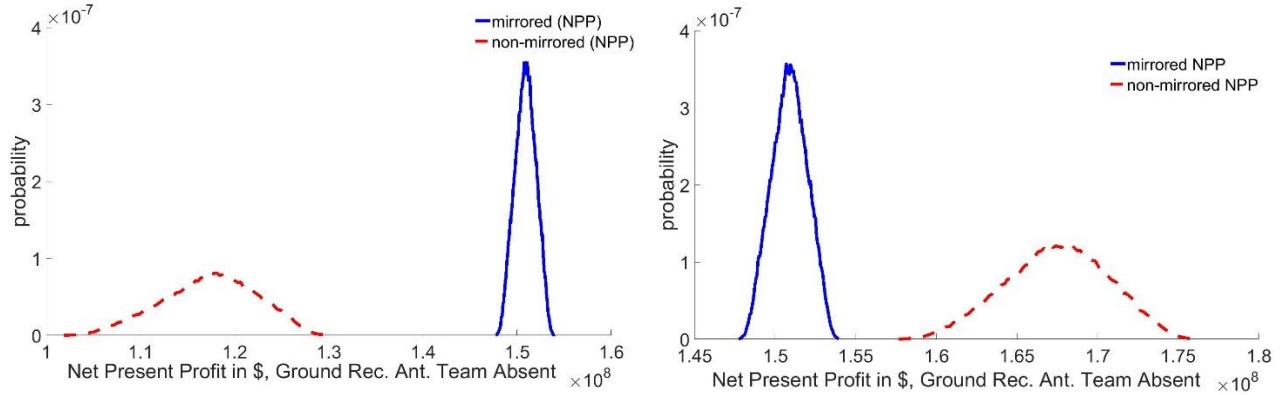

Figure 5.1: Probability Distributions of Net Present Profit for Design under Uncertainty

This is consistent with the results from the deterministic design study. This finding points to the ground receiving antennae having the largest impact on the value of the satellite system for the sample cases in this study. This is because, of the cases investigated, the organization structure change that affects the net present revenue is the ground receiving antennae team. It alludes to the possibility of using sensitivity information on not only attributes but also entire teams to make decisions that impact both the product and process in the design of this LSCES. Fig. 5.1a – f present the probability distributions of the net present profit for the Monte Carlo simulations whose mean net present profit values are presented in Table 5.5.

Given the various areas of organization design mentioned earlier, there are several aspects of an organizations structure that influence a system’s design. Observed and presented in this chapter is the inclusion of an organization characteristic in the value function of the satellite system which allowed for the observation of value impact of the satellite’s system’s organization structure on the design. Structural change that is a result of single decision maker alteration results in an error in the reported value of the satellite system showing that undesired change in the structure of LSCESs can be captured in the value function. Team decision making alteration of the satellite’s structure allowed for the observation of change to costs and revenue associated with the satellite.

This points to the possibility of using such information as added knowledge for decision making

when dealing with LSCESs. The results in the chapter have demonstrated that the assimilation of organization structure characteristics in the definition and valuation of LSCESs enables a deeper understanding of the interconnectivity of the design product with the design process[79]. The following chapter begins to address a formal approach to attain this goal.

CHAPTER 6: DETERMINISTIC DESIGN

In this chapter, the author discusses a methodology for the improved systems engineering modeling for LSCESs in a Value-Based Systems Engineering Framework. This is accomplished by the integration of OD in the evaluation of systems. To appropriately capture OD characteristics in a value function, the organization structures utilized to realize LSCES designs are considered. This attempts to successfully accomplish research objective 1 by formulating a value function to capture organization structure parameters. Specifically, the author proposes the representation of organization structure characteristics in value functions as the cost associated with the development effort and time that is made possible by the organization structures. This is made possible by considering two key aspects of an organization structure which are task execution and information links. The task execution accounts for the undertakings performed by each decision maker or group of decision makers. These decision makers are represented as the subsystems in the hierarchical decomposition of the complex system as presented in Fig. 3.1 and the hierarchical decomposition of the satellite system as illustrated in Fig. 4.2. Information links represent the allowable information exchanges between decision makers within the organization. These information links prescribe the authorized communication between entities in the organization thereby characterizing part of the organization's structure.

Organization Parameters

Within an organization structure, there are two types of tasks that can be performed by any given decision maker or group of decision makers namely, coordination tasks and specialization tasks. These two tasks are considered as the measures of decision makers' effort in this research. Specialization tasks are any effort that produces information that is unique to a specific decision maker or decision making team. Coordination tasks are any effort that results in the propagation

of information from one decision maker to another within an organization. These tasks are further broken down into the cost associated with each task as well as the time taken to execute the tasks. The tasks' cost and time parameters contribute to the systems value function. The costs add up to provide the cost of the organization while the times to execute tasks provide the duration to develop a specific design by summing up the times for the critical path in the system[17, 80, 81].

Critical Path

The critical path of a system development is the set of tasks that must be performed in sequence to complete a given objective. The objective with regard to the design of LSCESs is the establishment of a unique design that is identifiable by its design variables, characterized by its behavior variables and evaluated by the execution of an analysis to obtain the system value with regard to the value model for a given complex system. Fig. 6.1 illustrates an activity flow chart that represents the various tasks to be accomplished from start to end for an arbitrary system.

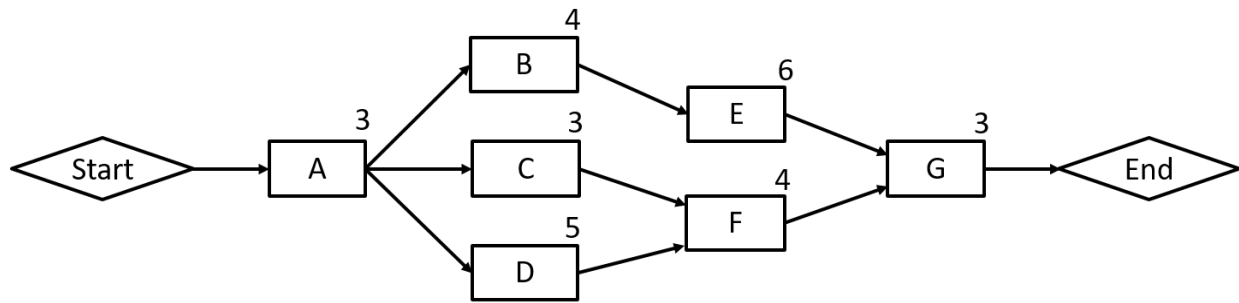

Figure 6.1: Activity Flow Chart for Critical Path Identification

The diamonds represent start and end of the entire process. The arrows show directional connectivity between activities i.e. the tail of the arrow is connected to the process that precedes the activity that is connected to the arrow head. The boxes represent the activities that need to be accomplished in order to complete the arbitrary design process illustrated in Fig. 6.1. The numbers

at the top right of each box represent the duration required to accomplish the task in the corresponding box. To identify the duration required to complete the design process illustrated above, the paths from start to end of the process are identified. There are three paths identifiable from Fig. 6.1 namely, 'A-B-E-G', 'A-C-F-G' and 'A-D-F-G'. Path 'A-B-E-G' has a total duration of 16 making it the longest path in terms of duration given that path 'A-C-F-G' has a duration of 13 and path 'A-D-F-G' has a duration of 15. This critical path calculation does not take into account the multiple and varied iterations required by various subsystems in order to accomplish various tasks. It also fails to account for the handling of information by higher level decision makers that act as managers to lower level decision makers. To accommodate this complexity, the following approach is formulated to handle the complexity of engineered systems.

The analysis of complex engineered systems involves iterations due to fully coupled subsystems as was briefly discussed in chapter 2. To account for the iterations that are necessary to complete a design analysis, the author employs the use of a hierarchic decomposition to isolate subsystem levels of the design processes. Once complete, the duration required for design at each subsystem level is obtained by calculating the maximum duration for executing tasks where the duration for coupled subsystems is the product of the duration per iteration by the number of iterations required to obtain consistency in the design variables and behavior variables of the coupled subsystems. Fig 6.2 illustrates the activity flow chart for an arbitrary system such as was presented in Fig. 6.1. In this setup, the dotted lines separate different subsystem levels. This allows for the activity durations to be examined by subsystem level. In the Fig. 6.2, the critical development path is 'A-D-F-G' with a duration of 30. The numbers in the parentheses represent the number of iterations required to attain consistency between design variables and behavior variables for the coupled subsystems.

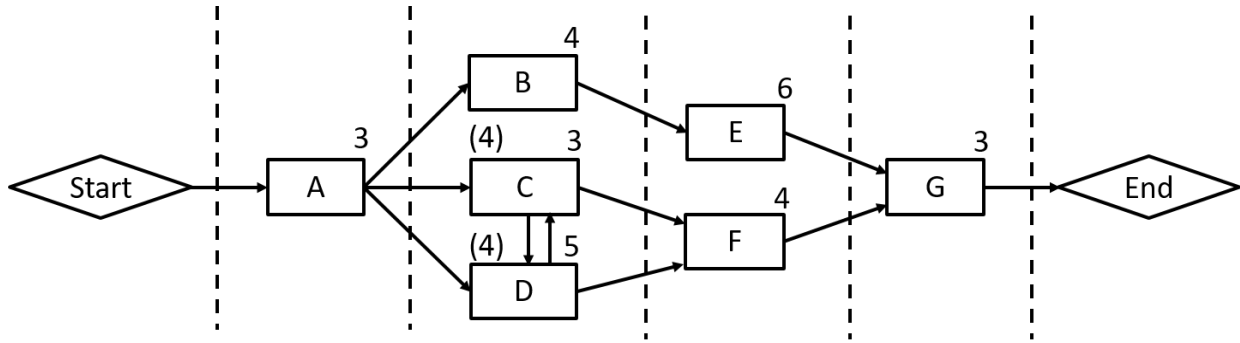

Figure 6.2: Activity Flow Chart for Critical Path Identification with Coupled Subsystems

Eq. 6.1 represents the total duration for the development used for complex systems to account for coupled systems present in different subsystem levels of LSCESs.

$$T_{dev} = \sum_{i=1}^n T_i \quad (6.1)$$

$$T_i = \max(\vec{t}_i) \quad (6.2)$$

where \vec{t} = vector of durations to execute tasks for a

given subsystem level and

i = subsystem level

The duration that is obtained from the critical path is then factored into the profit portion of the value function to account for the time value of money[17, 82, 83]. The organization cost calculation associated with the design is included in the calculation of the value function. For a complex engineered system in the commercial sector, stakeholders' preferences would appropriately be represented as a net present profit function (value function) where both the process and product are now accounted for in the value function. Eq. 6.3 represents a value function to represent profit where the organization cost is an addition to the typical formulation for establishing profit.

$$Profit = Revenue - Cost_{sys} - Cost_{org} \quad (6.3)$$

$$Cost_{org} = Cost_{spec} + Cost_{coord} \quad (6.4)$$

$$Cost_{spec} = Cost_{specS1} + \sum_{i=1}^2 Cost_{specSSLi} \quad (6.5)$$

$$Cost_{coord} = Cost_{coordS1} + \sum_{i=1}^2 Cost_{coordSSLi} \quad (6.6)$$

$$Cost_{specSSLi} = \sum_{j=1}^m (sc_j)S_j \quad (6.7)$$

where $m =$ number of subsystems in $SSLi$

$sc_j =$ number of specialization executions

for the j^{th} subsystem

$S_j =$ unit cost of specialization for the j^{th} subsystem

$$Cost_{coordSSLi} = \sum_{j=1}^m (cc_j)C_j \quad (6.8)$$

where $m =$ number of subsystems in $SSLi$

$cc_j =$ number of coordination executions

for the j^{th} subsystem

$C_j =$ unit cost of coordination for the j^{th} subsystem

Table 6.1 illustrates the durations per task and unit cost values assigned to the organization structure parameters for the system presented in Fig. 3.1. The figures themselves are assumed and do not represent a specific data set, but rather the trends present in organizations. These parameters are subject to different organization structures to investigate the effects of varying organization structures on system value.

Table 6.1: Organization Parameters for the Complex System

Organization Parameter	Unit Cost	Unit Task Duration (months)
Spec. S1 (V)	3.0	1.0
Spec. S11 (A111)	1.2	1.0
Spec. S12 (A121)	1.15	1.0
Spec. S21 (A211)	0.1	2.0
Spec. S22 (A221)	0.2	2.7
Spec. S23 (A231)	0.1	2.1
Spec. S24 (A241)	0.15	2.5
Coord. SSL1	0.075	0.25
Coord. SSL2	0.03	0.25

Organization Structures

The first organization structure incorporated into the value function of the complex system presented in Fig. 6.3 is a pure hierarchy.

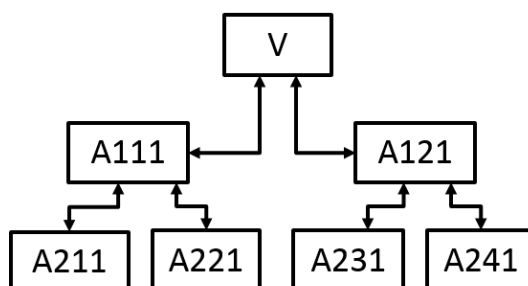

Figure 6.3: Pure Hierarchy Structure

In a pure hierarchy all information links are vertical, i.e. information is passed up to a managing entity or passed down from a managing entity. There are no lateral information links that permit the passing of information to and from entities within the same level of an organization. In the evaluation of the cost of the organization on the design process, the total cost of developing a design is obtained from a two part summation. The products of the cost to execute a single task (specialization cost) and the number of tasks executed during an analysis for each entity in the

organization are summed with the products of the cost to relay information (coordination cost) and the number of times an entity in the organization relays information during the analysis to evaluate a design of the complex system (Eq. 6.4 to Eq. 6.8). Information on the total organization costs associated with task specialization, task coordination and duration of system development are collected and presented later in this paper. Fig. 6.4 is an illustration of the pure hierarchy structure with information links.

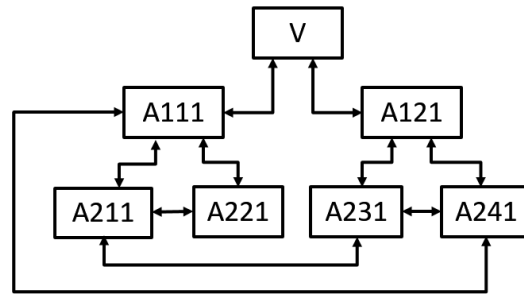

Figure 6.4: Completely Mirrored Structure

The second organization structure the system is tested against is a completely mirrored structure. In complete mirroring, the organization structure is designed to mimic the physics-based structure of the system to be developed. As such, the couplings (information on physics-based relations in the system) are represented as information links (organization couplings) in the organization structure. Fig. 6.4 is an illustration of the complete mirroring structure with information links.

As a third structure, a partially mirrored structure is used in the analysis of the system's value. Fig. 6.5 illustrates this partial mirroring. It differs from the complete mirroring as a result of the exclusion of a direct information link between A_{211} and A_{231} .

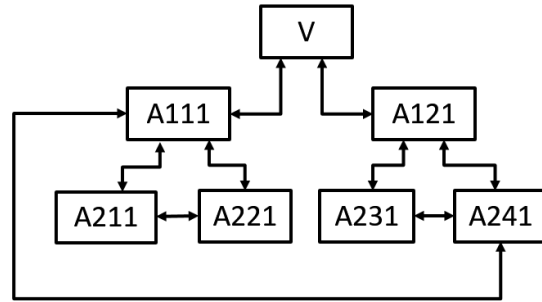

Figure 6.5: Partially mirrored structure with no direct link from A211 to A231

With this partial mirroring, the costs associated with the organization are calculated. The duration to develop the system for the given set of design variables is also calculated. These attributes are used to calculate the system's value which includes the physics-based product as well as the process. The final organization structure that is used to observe the impact of organization structures on system value in this work is another partial mirroring. This structure differs from the complete mirroring by virtue of lacking a direct information link from A₂₄₁ to A₁₁₁.

The partial mirroring structure is used as a demonstration of the possibility to use organization structures that only contain mirroring in parts of the organization and not the entire organization. This can be due to various restrictions imposed either within or upon the organization that prevent the organization from adopting a complete mirroring. Similar to the data collected on the organization structures above, the costs and duration for development are calculated and presented in Table 6.2.

Table 6.2: Complex System Value with Different Structures

Org. Structure (mirrored link)	System Value w/o Dev. Time	System Value w/ Dev. Time	Δ in System Value	Δ in System Value w/ Dev. Time	Coord. Cost	Δ in Coord. Cost	Org. Cost	Δ in Org. Cost	% Δ in System Value w/o Dev. Time	% Δ in System Value w/ Dev. Time
Pure Hierarchy	68.55	55.17	0.00	0.00	4.30	0.00	14.75	0.00	0.00	0.00
Complete Mirror	71.38	60.75	2.83	5.58	1.47	-2.83	11.92	-2.83	3.96	9.19
Partial Mirror (A241 – A111)	71.10	60.45	2.55	5.28	1.75	-2.55	12.20	-2.55	3.59	8.74
Partial Mirror (A211 – A231)	71.33	60.71	2.78	5.54	1.52	-2.78	11.97	-2.78	3.90	9.13

It is observed from the sample data set presented in Table 6.2 that, for this example with three (3) hierarchical levels and seven (7) subsystems, the best organization structure for this complex system, in terms of system value at 71.38, is the complete mirroring structure where the physics-based system that was presented in Fig. 3.1 has a structure with organization couplings that mirror its own physics-based couplings as was presented in Fig. 6.4. The complete mirroring has the lowest overall coordination cost and therefore the lowest organization cost given that the specialization costs are the same for all organization structures to which the system is subjected for a specific design. A similar trend of system value was observed for several data points supporting the findings that the complete mirroring is the best structure for this complex system in terms of system value. There is a greater percentage difference in the system value between the pure hierarchy structure and the other structures when a discount rate is introduced to the system value due to the time taken to develop the system. The discount rate is used to adjust the projected system value by representing future dollar sums in terms of present dollars. This difference is a

direct result of the discount rate applied to the value function and points to the importance of capturing time as a parameter to the design of complex systems especially where revenue and cost are affected by duration to deliver an engineered system.

A survey of the design space was conducted to investigate the relationship of system value with regard to organization structures. All design variable sets produced results similar to those presented in Table 6.2. In particular, the completely mirrored structure consistently provided the highest system value for the values that incorporate development time and the values that do not incorporate development time. Appendix B presents the numerous sets of design variables that were sampled throughout the design space associated with the complex system introduced in Chapter 3. Following the design variable sets in appendix B is a tabulation of the system values associated with the survey highlighting the system value with varied organization structures as presented above. Fig. 6.6 illustrates the percentage changes in system value for all the design variable sets that are represented in Appendix B. These changes are in reference to the system values for the pure hierarchy structure at each design point as shown by the table in Appendix B.

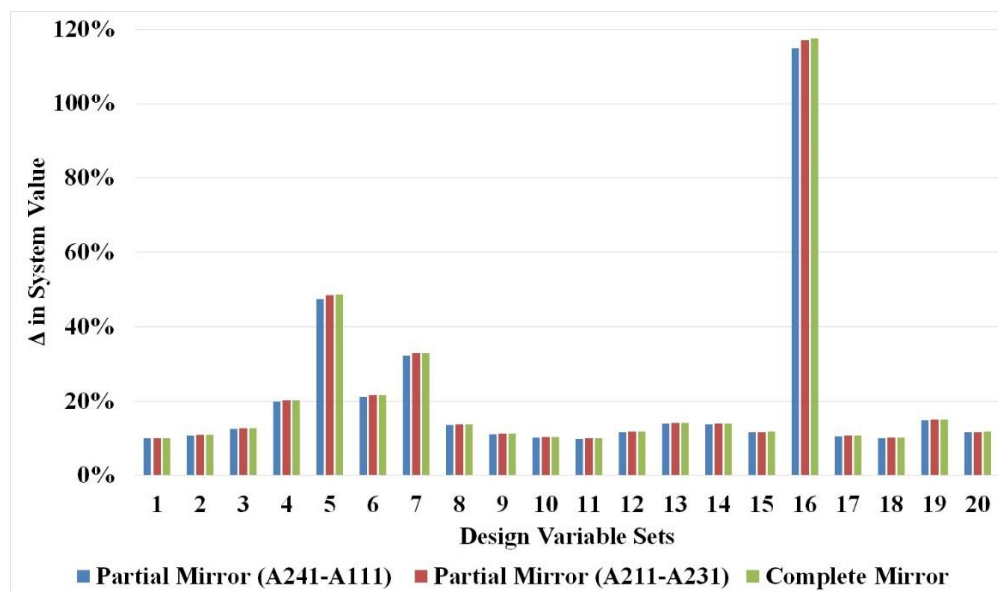

Figure 6.6: Change in Value for Organization Structures as Presented in Appendix B

Noteworthy to the impact of organization structures on the design of engineered systems is that the parameters that dictate the unit costs for coordination and specialization have a huge impact on the system value at any given point in the design space. This also determined which of the two partial mirroring structures resulted in a system with higher value. The dependence on organization structures to provide higher system values (partial mirroring), points to the potential importance of the role an organization's structure can play on the systems that organizations design.

Coupling Strengths

The role of coupling strengths on the design of engineered systems is investigated in this work where, the value of the system includes the costs associated with the organization. Coupling impacts can be mathematically captured by calculating the total derivatives that represent the total change in system value due to a change in an attribute. A change in system value due to a change in a specific attribute is mathematically represented by Eq. 6.9. The total derivative term on the right hand side of the equation can be solved in terms of partial derivatives and is discussed in detail using a simple example in the forthcoming sections.

$$\frac{dV}{dA_{x,y,z}} = \frac{\partial V}{\partial A_{x,y,z}} + \sum_{p=1}^P \left(\frac{\partial V}{\partial A_{0,1,p}} \frac{dA_{0,1,p}}{dA_{x,y,z}} \right) \quad (6.9)$$

Here, x is the level number (0 being the system level to N being the total number of levels), y is the subsystem number, z is the attribute number, V is the value function, which is a function of system level attributes (such as $f(A_{0,1,1}, A_{0,1,2}, A_{0,1,3}, \dots, A_{0,1,P})$), and P is the number of attributes at the system level. In order to compare the coupling strengths, their values are normalized as illustrated in Eq. 6.10, where i represents a given design point.

$$\left(\frac{dV}{dA_{x,y,z}}\right)_{norm,i} = \left(\frac{dV}{dA_{x,y,z}}\right)\left(\frac{V_i}{A_{x,y,z_i}}\right) \quad (6.10)$$

Using the four organization structures as presented in the section above, two couplings are suspended and the system values calculated to evaluate the impact of the coupling suspension on the system value. An as example, the two attributes associated with the couplings investigated in this section are A_{211} and A_{241} . An analysis on the system to obtain value is then performed with each of the organization structures presented earlier in this work. This is accomplished by setting the value for each attribute to ten percent (10%) less than the converged value without coupling suspension and evaluating the system value to determine which organization structure provides the smallest deviation in value.

Table 6.3: Complex System Value under Coupling Suspension

#	Org. Structure (mirrored link)	System Value w/o Dev. Time	System Value w/ Dev. Time	Δ in System Value	Δ in System Value w/ Dev. Time	Spec. Cost	Coord. Cost	Org. Cost	% Δ in System Value w/o Dev. Time	% Δ in System Value w/ Dev. Time
1	Pure Hierarchy	68.55	55.17	0.00	0.00	10.45	4.30	14.75	0.00	0.00
2	Pure Hierarchy	62.64	54.01	-5.91	-1.16	8.55	3.01	11.56	-8.63	-2.11
3	Pure Hierarchy	78.38	71.63	9.83	16.46	7.55	1.96	9.51	14.34	29.83
1	Complete Mirror	71.38	60.75	2.83	5.58	10.45	1.47	11.92	0.00	0.00
2	Complete Mirror	64.63	62.46	-3.92	7.29	8.55	1.02	9.57	-9.46	2.82
3	Complete Mirror	79.65	71.20	11.10	16.03	7.55	0.72	8.24	11.59	17.20
1	Partial Mirror (A241 – A111)	71.10	60.45	2.55	5.28	10.45	1.75	12.20	0.00	0.00

Table 6.3: (Continued)

2	Partial Mirror (A241 – A111)	64.32	62.07	-4.23	6.90	8.55	1.33	9.88	-9.54	2.67
3	Partial Mirror (A241 – A111)	79.42	70.87	10.87	15.70	7.55	1.00	8.48	11.70	17.24
1	Partial Mirror (A211 – A231)	71.33	60.71	2.78	5.54	10.45	1.52	11.97	0.00	0.00
2	Partial Mirror (A211 – A231)	64.58	62.41	-3.97	7.24	8.55	1.07	9.62	-9.47	2.81
3	Partial Mirror (A211 – A231)	79.54	71.09	10.99	15.92	7.55	0.80	8.35	11.51	17.10

Table 6.3 contains the evaluations of the systems value under the coupling suspension when subjected to the four organization structures. Attribute A_{211} has a normalized coupling strength of -0.7369 at the design point selected. Attribute A_{241} has a normalized coupling strength of -0.1921. A negative value for a coupling strength indicates that a negative change in the attribute value would result in a positive change in the system value, while a positive value for the coupling strength provides a relationship that is the inverse to that of the negative coupling strength scenario. As such, A_{211} will result in a larger change in the physics-based value of the system for the same percentage change in value as that of A_{241} . In table 6.3, all rows numbered 1 correspond to evaluations without coupling suspension. Those numbered 2 correspond to evaluations with the suspension of A_{211} and those numbered 3 correspond to the suspension of A_{241} . It is observed that of the four structures, the pure hierarchy has the lowest system value both with and without the

inclusion of development time. Of the two attributes that were suspended, it is observable that the higher system value is obtained from the coupling suspension with a lower normalized coupling strength, A_{241} . This is because, for this particular example, with a lower normalized strength, there is more value gained in fewer task execution iterations and task coordination executions compared to the loss in value due to the change in the attribute A_{241} . This observation is reinforced by the lower changes in organization cost when compared to those that accompany the coupling suspension associated with A_{211} . Based on these results, coupling strength information can be used when accompanied by the appropriate representation of organization structure attributes in a value function to assess trade-offs between revenue and cost of a system especially where resources are scarce and would require sacrifices to be made.

Given the findings on the impact an organization structure can have on an engineered system's value based on the composition of a value function, it is the opinion of the author that adding the evaluation of a system's organization structure to its physics-based attributes in a value function will improve the accuracy of predictive modeling of LSCESs and expand the platform for more informed and unified decision making throughout the design and development of LSCESs. The following section of this work demonstrates the application of this augmentation to the design process associated with the modeling of a commercial communication satellite.

Satellite System Organization Parameters

The satellite system's organization structures are characterized by information pathways that join decision makers, and the placement of these decision makers within the organization. These are represented in a value system as the time and cost associated with task execution. The time for execution is split into two: the time to conduct specialization tasks and the time to conduct coordination tasks. Similarly, costs are measured as costs associated with specialization tasks and

those associated with coordination tasks as previously discussed. This work presents the difference in organization structures and the projection of these differences on the value of the system. A number of assumptions are made on the LSCES to include the organization structure in the value function. To begin, all individuals in the organization that are working on designing the system reside in one of the subsystems presented in the decomposed system as illustrated in Fig. 6.7.

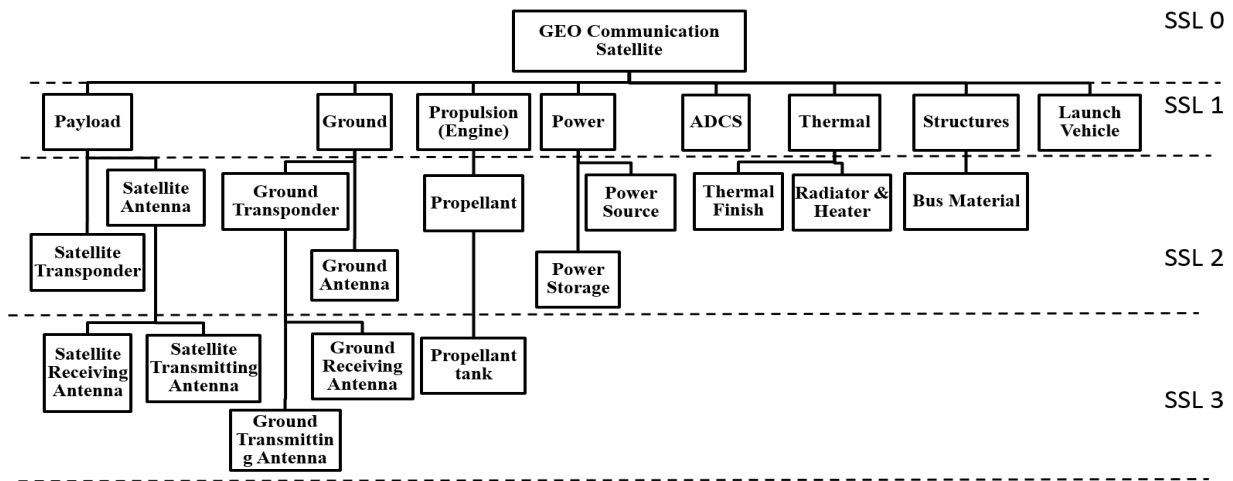

Figure 6.7: Hierarchical Decomposition of Communication Satellite System

A decision maker is considered as either an individual or a team of individuals responsible for making specific selections from sets of possible alternatives. The subsystems present in the satellite system therefore also represent decision making teams with multiple decision makers being responsible for choices that affect behavior variables and/or attributes in the organization structure. A value function was established to account for the organization structure characteristics in order to allow for the revaluation of the satellite system. This was accomplished by attributing specialization and coordination times and costs to each subsystem. For a given aircraft design, there is a cost associated with a computational fluid dynamics analysis as is the case with a finite element analysis to determine structural integrity. The summation of the products of these

specialization and coordination tasks with the number of times each is executed is added to the cost portion of the value function. Similarly, the net present profit (NPP) of the satellite system takes into account the organization costs which are dependent on these tasks. The NPP function developed by Dr. Kannan[61, 65] is presented in Eq. 6.11. The organization cost, as presented in Eq. 6.12 is added to the satellite cost and the resulting function provides the new NPP equation used as presented in Eq. 6.14.

$$V = f(\text{Satellite Cost, Revenue}) = -\text{Satellite Cost} + \sum_{y=1}^{OL} \frac{\text{Revenue}_y}{(1 + r_d)^y} \quad (6.11)$$

$$\begin{aligned} r_d: & \text{discount factor} = 10\% \\ OL: & \text{Operational Lifetime} = 10 \text{ years} \\ y: & \text{year} \\ \text{Org Structure Cost} = & \sum_{n=1}^s n_c * c_{\text{cost}_n} + \sum_{n=1}^s n_s * s_{\text{cost}_n} \end{aligned} \quad (6.12)$$

c_{cost_n} : cost of coordination of subsystem n
 c_{cost_n} : cost of coordination of subsystem n
 s : total number of subsystems
 n_c : number of coordination executions
 n_s : number of specialization executions
 n : subsystem index

$$\text{Total Cost} = \text{Satellite Cost} + \text{Org Structure Cost} \quad (6.13)$$

$$V = f(\text{Total Cost, Revenue}) = (-\text{Total Cost} + \sum_{y=t_{dev}}^{OL+t_{dev}} \frac{\text{Revenue}_y}{(1 + r_d)^y}) \quad (6.14)$$

r_d : discount factor = 10%
 t_{dev} = development time rounded up to years
 OL : Operational Lifetime = 10 years
 y : year

The parameters associated with the coordination costs and coordination times are assumed as represented in Table 6.4 below where there is an increased unit cost and unit time with regard

to a higher subsystem level in which a subsystem is classified. The greater the subsystem level designation, the further down the hierarchy the subsystems in that level are found.

Table 6.4: Subsystem Level Coordination Cost and Time Allocation

Subsystem Level	Cost/coordination	Time/Coordination
0	\$100,000	2.5 weeks
1	\$50,000	2 weeks
2	\$20,000	1.5 weeks
3	\$10,000	1 week

The parameters associated with the specialization costs are assumed as represented in Table 6.5, where coordination costs are constant across a given subsystem level, the specialization costs associated with subsystems in a given subsystem level are of the same order of magnitude but vary depending on the subsystem. Along with these costs, specialization times are also assigned. When specialization times and coordination times are tallied, they provide the total time required to develop the LSCES in question. This duration for development affects the revenue to be developed by virtue of the discount factor.

Table 6.5: Subsystem Specialization Cost and Time Allocation

Subsystem	Cost/Specialization	Time/Specialization (weeks)
Comm. Satellite (Geo)	\$1,000,000	5
Payload	\$330,000	2
Ground	\$320,000	2
Engine	\$300,000	2.5
Power	\$280,000	1.5
ADCS	\$400,000	3
Thermal	\$300,000	2
Structures	\$350,000	2.5
Launch Vehicle	\$500,000	3

Table 6.5: (Continued)

Satellite Transponder	\$130,000	5
Satellite Antenna	\$115,000	7
Ground Transponder	\$110,000	6
Ground Antenna	\$120,000	7.5
Propellant	\$110,000	8
Power Source	\$125,000	6.5
Power Storage	\$110,000	5.5
Thermal Finish	\$100,000	6
Radiator & Heater	\$120,000	7
Bus Material	\$120,000	7
Satellite Transmitting Antenna	\$36,000	5
Satellite Receiving Antenna	\$40,000	4
Ground Transmitting Antenna	\$36,000	3
Ground Receiving Antenna	\$40,000	3
Propellant Tank	\$50,000	4

Satellite Organization Structures

Given the establishment of all the organization parameters presented above, the next step of the organization evaluation for the satellite system involves the utilization of an organization structure on the LSCES. To begin, the organization structure used is a standard pure hierarchy. A pure hierarchy is characterized by the vertical flow of information from one subsystem to another. This involves having managers controlling the flow of information throughout the organization. In particular, information that is to move from one subsystem to another subsystem within a given subsystem level must be controlled by at least one entity that exists in the subsystem level above the level with the information source. In the case of the satellite system, for the information on the mass of the payload, this information is passed up to the project lead present in the system level (Geo) who then passes this information down to the lead of the structures subsystem. The organization cost associated with the design and development of the satellite system is then

calculated by obtaining the analysis cost and time. The analysis time is specifically calculated by determining the critical development path that gives the anticipated development time. Table 6.6 represents the analysis in terms of the number of task executions associated with specialization

Table 6.6: Pure Hierarchy Task Execution Count

Pure Hierarchy	Coordination Count	Specialization Count
Comm. Satellite (Geo)	95	1
Payload	4	2
Ground	1	1
Engine	11	9
Power	23	9
ADCS	12	7
Thermal	11	6
Structures	7	7
Launch Vehicle	9	9
Satellite Transponder	1	1
Satellite Antenna	3	1
Ground Transponder	1	1
Ground Antenna	3	1
Propellant	2	1
Power Source	5	5
Power Storage	1	1
Thermal Finish	1	1
Radiator & Heater	1	1
Bus Material	1	1
Satellite Transmitting Antenna	1	1
Satellite Receiving Antenna	1	1
Ground Transmitting Antenna	1	1
Ground Receiving Antenna	1	1
Propellant Tank	1	1

and coordination tasks for each of the subsystems that make up the satellite system when design is undertaken within a pure hierarchy organization structure.

Table 6.7 presents this information on the value of the system with regard to the geostationary commercial communication satellite in terms of the net present profit.

Table 6.7: Pure Hierarchy Satellite System Value

Pure Hierarchy		
Development Time	3.35 years	
Organization Cost	\$34,432,000	
Net Present Profit	Perceived	\$307,226,000
	w/ Org. Structure	\$272,794,000

It is observed that the NPP of the satellite system is lower than the perceived value of the system when the cost of the organization structure is not included. Additionally, the coordination effort undertaken by each subsystem increases the further up the hierarchy a subsystem exists. The inclusion of the nature in which decision makers interact as prescribed by an organization structure, as in the examples herein, can provide invaluable information. This information can allow for more informed decision making that includes, but is not limited to, the undertaking of system development.

The second evaluation performed to determine the plausibility of capturing organization parameters on system value is achieved through the evaluation of a mirrored organization structure. This mirrored structure is determined based on the hierarchical decomposition of the geostationary commercial communication satellite. Given the numerous types of decompositions available, a mirrored structure can take the form of any physics-based decomposition on an LSCES. The mirrored structure in this case therefore mimics the physics-based hierarchic

decomposition that was presented in Chapter 4. Information passed from one entity to another in the mirrored structure can be vertical, from one subsystem level to another, horizontal, from one subsystem to another within the same subsystem level, or a combination of both. Table 6.8 represents the analysis in terms of the number of task executions associated with specialization and coordination tasks for each of the subsystems that make up the satellite system when design is undertaken within a mirrored organization structure. An analysis that yields the cost of the organization as well as the development time is performed.

Table 6.8: Mirrored Task Execution Count

Mirrored Structure	Coordination Count	Specialization Count
Comm. Satellite	0	1
Payload	2	2
Ground	1	1
Engine	9	9
Power	9	9
ADCS	21	7
Thermal	12	6
Structures	28	7
Launch Vehicle	9	9
Satellite Transponder	3	1
Satellite Antenna	1	1
Ground Transponder	1	1
Ground Antenna	1	1
Propellant	2	1
Power Source	10	5
Power Storage	3	1
Thermal Finish	2	1
Radiator & Heater	2	1
Bus Material	1	1
Satellite Transmitting Antenna	3	1

Table 6.8: (Continued)

Satellite Receiving Antenna	3	1
Ground Transmitting Antenna	2	1
Ground Receiving Antenna	2	1
Propellant Tank	2	1

It is observed that the mirrored structure analysis demonstrates that for mirroring, the coordination effort is spread throughout the organization as opposed to being focused at the top of the organization as was observed with the pure hierarchy. Table 6.9 presents the information on the value of the system with regard to the satellite system (LSCES) in terms of the net present profit for the mirrored structure development.

Table 6.9: Mirrored Structure Satellite System Value

Pure Hierarchy		
Development Time	2.58 years	
Organization Cost	\$25,732,000	
Net Present Profit	Perceived	\$307,226,000
	w/ Org. Structure	\$281,494,000

The evaluations presented above of the satellite system with differing structures validate the capturing of LSCES value where the organization parameters are included in the definition of system value. The identification of the mirrored structure providing a lower organization cost by \$8,700,000 supports the mirroring hypothesis. This information can be used in the design of organization structures for organizations that are restricted by factors that do not permit complete mirroring of structures to physics-based decompositions. In particular, a hybrid mirrored structure

to be developed should contain a complete mirroring in regions of the organization that have highly coupled systems.

The work in this chapter focused on deterministic design[84, 85]. LSCESs however have uncertainty associated with their organization parameters just as they do with their physics-based variables. Given uncertainty exists in the design of LSCESs, decision makers are faced with risky decision whose choices are subject to their risk attitudes. As a result, chapter 7 entails investigation on how uncertainty present in organization structures affects the design of LSECSs through value modeling.

CHAPTER 7: STOCHASTIC DESIGN

The author, in this chapter, explores the effects of using the value modeling of LSCESs introduced in Chapter 6 while considering uncertainty presence in organization design. By doing so, this chapter will provide the accomplishment of research objective 2, which is to develop a method to capture uncertainty associated with organization structures in value modeling of LSCES. In particular, the uncertainty on task execution duration associated with specialization and coordination is investigated to understand how uncertainty in organization structures and by extension, organization design, affects the system modeling of LSCESs by observing the measurable changes to system value. Herein, uncertainty is represented as probability distributions of organizational parameters[86].

Organization Parameters

In order to establish the effects of uncertainty in the organization structure on the value of the system, a number of Monte Carlo simulations are conducted. Table 7.1 shows the organizational structure peak values associated with triangular distributions that are used for the analyses of the system presented in Chapter 3 to obtain system values. Throughout the study, the physics-based variables and parameters are maintained as deterministic measures so that the resulting distributions reflect only the uncertainty from the organization structures.

For the task costs associated with the organization structures, the triangular distributions are obtained by having the upper limit being 5, 15 and 25 percent greater than the peak values presented in Table 7.1. Similarly, the lower limits for these triangular cost distributions are established by having them as 5, 15 and 25 percent lower than the peak values availed in Table 7.1. With regard to the variation in task times, the triangular distributions were established by having the limits be 10 percent above and below the peak values in Table 7.1 to obtain the upper

and lower limits. It must be noted that for this study, the distributions are all symmetric about the peak values presented. Variations in the types of distributions associated with organization structure parameters will be addressed in future work as is discussed later in this paper. To capture effects of an analysis with and without development time, during the study a distribution on task time was only employed where there was a distribution on task cost.

Table 7.1: Organization Parameter Peak Values.

Organization Parameter	Unit Cost	Unit Task Duration (months)
Spec. S1 (V)	3.0	1.0
Spec. S11 (A111)	1.2	1.0
Spec. S12 (A121)	1.15	1.0
Spec. S21 (A211)	0.1	2.0
Spec. S22 (A221)	0.2	2.7
Spec. S23 (A231)	0.1	2.1
Spec. S24 (A241)	0.15	2.5
Coord. SSL1	0.075	0.25
Coord. SSL2	0.03	0.25

Uncertainty Analysis

The first study involves analyses on the system with all organization structures aforementioned where the uncertainty is present on only one of the tasks. In particular, this involves uncertainty on a specialization cost associated with a specialization task. Herein, the authors present the results associated with uncertainty on the specialization of subsystem S24. This is conducted with the three distributions (5%, 15% and 25%) as previously mentioned. Figure 7.1 illustrates the distribution obtained for the Monte Carlo simulation for a 25% variation from peak values of the triangular distribution for the specialization cost associated with subsystem S24. This system value distribution for the simulation associated with the analysis does not account for task times and therefore does not take into account system development time in the evaluation

procedure. Figure 7.2 is the value distribution associated with the system analysis where development time is incorporated in the calculation of value.

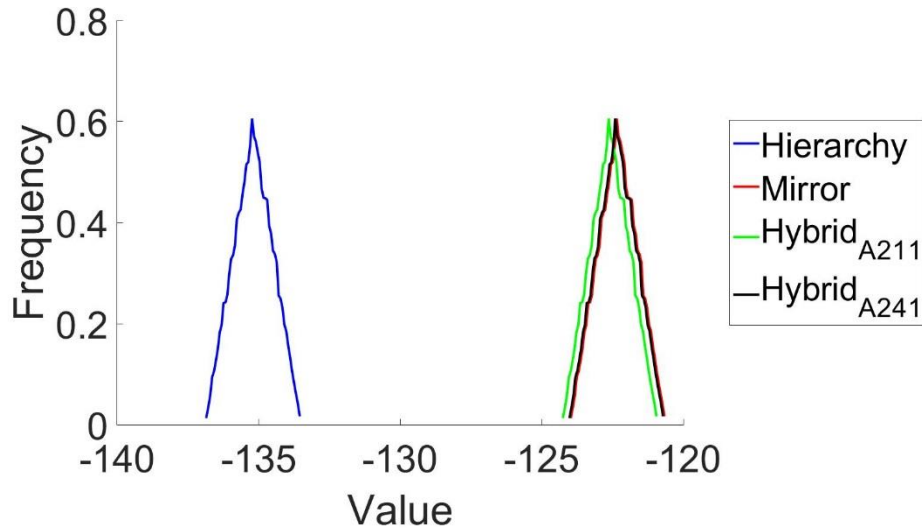

Figure 7.1: System Value with Uncertainty in Specialization of S24

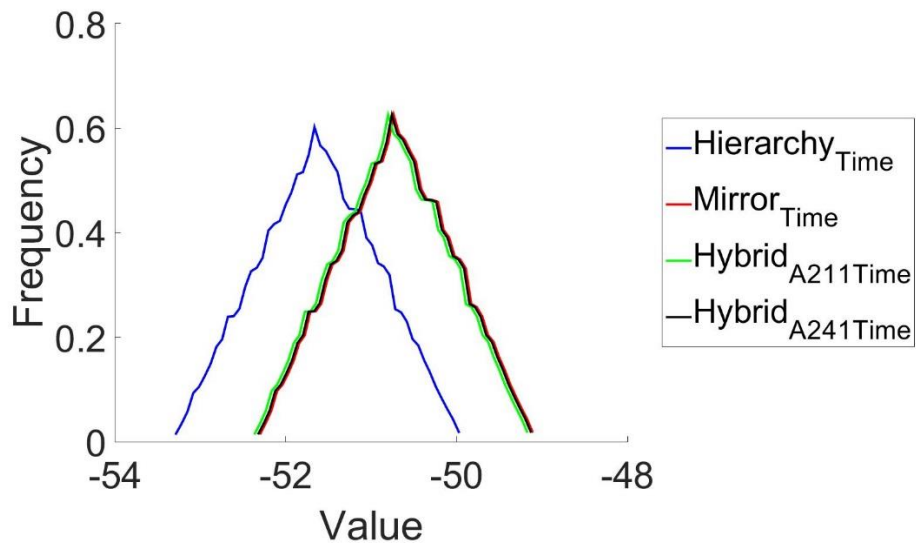

Figure 7.2: Time Dependent System Value with Uncertainty in Specialization of S24

The greatest mean system value for this analysis is obtained from the complete mirroring structure which is -122.32 for the simulation that does not include the development time and -50.70 for the analysis that includes development time, where there is uncertainty associated with

the task time for subsystem S24 that has a variable cost. The lowest mean system values were obtained from the pure hierarchy structure as -135.2 without development time and -51.6 with development time. This information shows that for this system model, there is an increased level of system value uncertainty as a result of variation in development time as would be expected. When tests were performed with a greater percentage on uncertainty on the triangular distribution with regard to the task times, the system value distributions had mean values that were even closer than those in Fig. 7.2 as opposed to variations in task costs. The Monte Carlo simulation conducted on the system with variation on only one task cost and task time were repeated with subsystem S12. The mean system values obtained are the same as those obtained with the subsystem S24 for the pure hierarchy and the complete mirroring structures. Fig. 7.3 and Fig. 7.4 represent the system value distributions associated with uncertainty on the specialization task associated with subsystem S12. A significant difference in the system values obtained between the analyses where uncertainty exists in subsystems S24 and S12 is the range of values. Subsystem S24 is fully coupled with subsystem S23 which requires a greater number of subsystem evaluations to obtain a consistent solution thus creating a greater range in system value distributions.

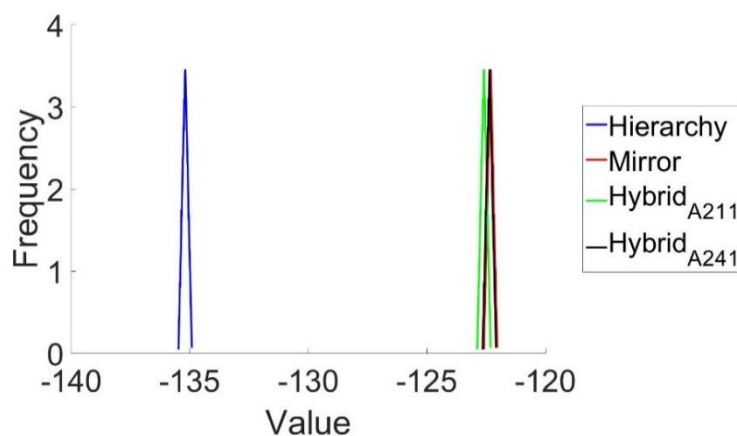

Figure 7.3: System Value with Uncertainty in Specialization of S12

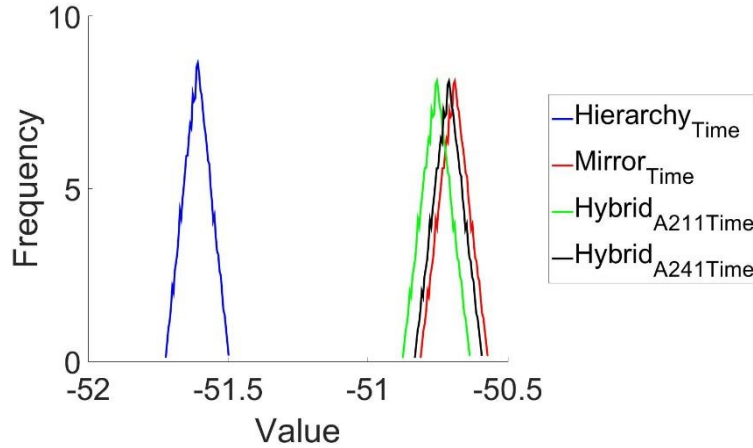

Figure 7.4: Time Dependent System Value with Uncertainty in Specialization of S12

The second study involves the analyses on the system where multiple tasks have uncertainty imposed upon them. In particular, the results presented discuss the system value distributions that result from combinations of uncertainty on tasks associated with subsystems S12 and S24. In this case, the results are very similar to those obtained for the simulation where only subsystem S24 is subjected to uncertainty in task cost and time. Fig. 7.5 and Fig. 7.6 are illustrations of the system value distributions that are obtained from the mentioned Monte Carlo simulations. This reinforces the idea that the propagation of uncertainty from organizational parameters to system value, for this system model, is greater where uncertainty exists in parameters that are fully coupled as opposed to those that are partially coupled. That is to say, there is greater risk involved in the outcomes when fully coupled entities are subject to uncertainty. A repetition of this simulation with only costs being subject to uncertainty where task time was deterministic yielded the similar distributions suggesting that it is the coupling that drives the multiple iterations within the analysis to produce system value distributions with larger ranges than those that have partially coupled entities subject to uncertainty.

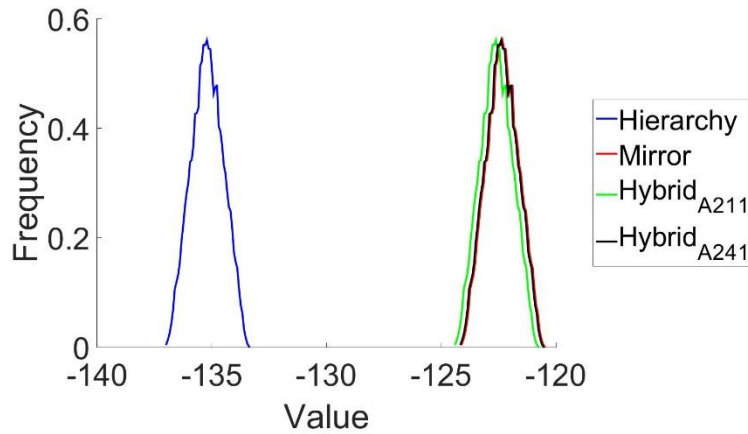

Figure 7.5: System Values for Uncertainty in Subsystems S12 and S24

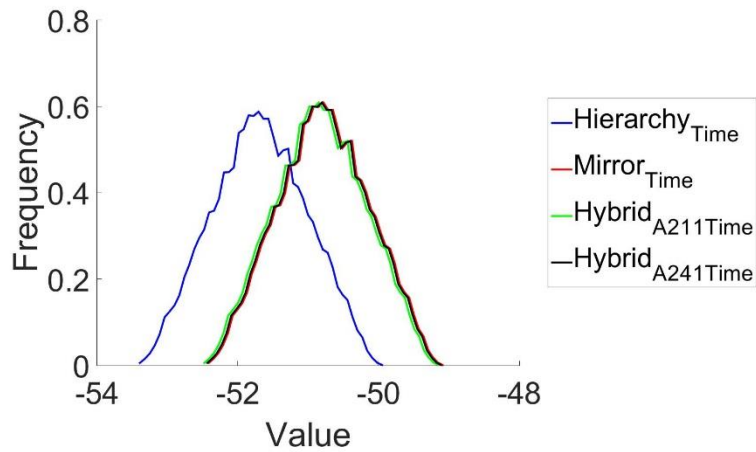

Figure 7.6: Time Dependent System Values for Uncertainty in Subsystems S12 and S24

Based on the authors' findings in Chapter 6 that shows the most significant difference between organization structures as applies to system value is the coordination effort, the next study involved the application of uncertainty to only the coordination tasks for all subsystems. This was done with and without the inclusion of development time.

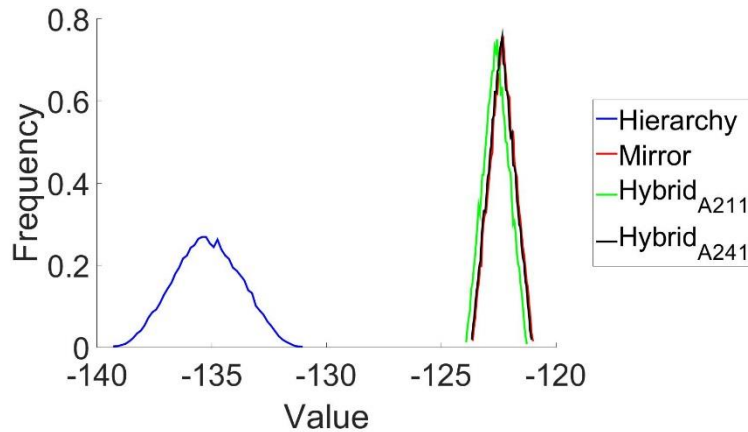

Figure 7.7: System Values for Uncertainty in Coordination Tasks

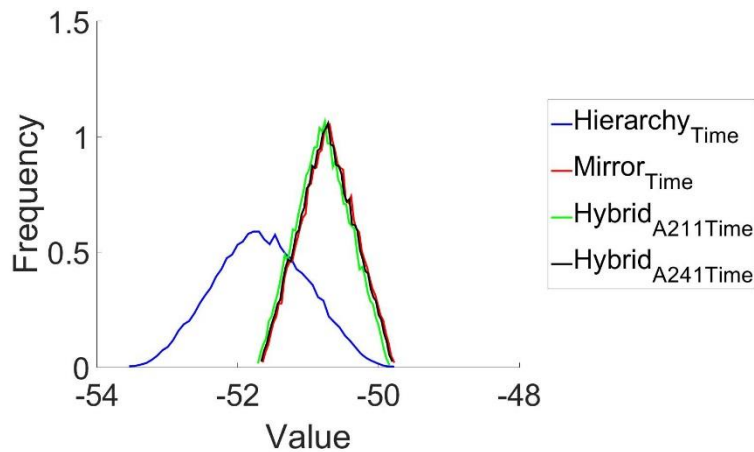

Figure 7.8: Time Dependent System Values for Uncertainty in Coordination Tasks

Fig 7.7 and Fig. 7.8 demonstrate the distributions that are obtained as a result of these simulation. There is a stark contrast in the system value distributions obtained from this simulation than the first two studies. Whereas the nature of the distributions was not vastly different between organization structures for each study for both cases with the inclusion and exclusion of development time, there is a noticeable difference between the pure hierarchy structure and the other structures. It can be observed that in both cases, the pure hierarchy structure produces a distribution that is a lot broader than the other structures. In particular, the range for the pure

hierarchy without development time is 8.36 while that of the complete mirroring is 2.67. This is just over thrice the breadth. A similar trend is observed in the comparison where development time is included in the value function with the pure hierarchy having a range of 3.82 and the complete mirroring having a range of 1.90 equating to about twice the breadth. This would suggest that, for this complex system model, the coordination effort throughout a system has a greater effect on system value uncertainty depending on the organization structure adopted for development endeavors. Given this finding, similar studies are conducted on the satellite system model that was first introduced in Chapter 4.

Satellite System Organization Parameters

The evaluation of the satellite system to determine the role of organizational uncertainty in conducted with respect to two organizational structures as was presented in Chapter 6. These are the pure hierarchy structure and the complete mirrored structure. As was done in the previous sections of this chapter, the uncertainty that is represented in the satellite system is only on the organization structure parameters, i.e. specialization and coordination tasks. Similarly, the parameters that are subject to uncertainty are represented as triangular distributions. Table 7.2 is the peak values for the task costs and times associated with the specialization for each subsystem as well as the coordination for all tasks within each subsystem level.

Table 7.2: Satellite Organization Peak Task Values

Subsystem	Task Cost	Task Duration (weeks)
Comm. Satellite (Geo)	\$1,000,000	5
Payload	\$330,000	2
Ground	\$320,000	2
Engine	\$300,000	2.5
Power	\$280,000	1.5
ADCS	\$400,000	3

Table 7.2: (Continued)

Thermal	\$300,000	2
Structures	\$350,000	2.5
Launch Vehicle	\$500,000	3
Satellite Transponder	\$130,000	5
Satellite Antenna	\$115,000	7
Ground Transponder	\$110,000	6
Ground Antenna	\$120,000	7.5
Propellant	\$110,000	8
Power Source	\$125,000	6.5
Power Storage	\$110,000	5.5
Thermal Finish	\$100,000	6
Radiator & Heater	\$120,000	7
Bus Material	\$120,000	7
Satellite Transmitting Antenna	\$36,000	5
Satellite Receiving Antenna	\$40,000	4
Ground Transmitting Antenna	\$36,000	3
Ground Receiving Antenna	\$40,000	3
Propellant Tank	\$50,000	4
Coord. SSL 0	\$100,000	2.5
Coord. SSL 1	\$50,000	2
Coord. SSL 2	\$20,000	1.5

Satellite Uncertainty Analysis

Based on the organization structure parameters presented above for the satellite system, a Monte Carlo simulation is used to obtain the system value probability distributions corresponding to applied organization structures. Following the template of the satellite evaluation in Chapter 6, a pure hierarchy and a completely mirrored structure are used to capture the organization design inclusion in the value modeling of the satellite system. The pure hierarchy represents the current set up of organization structures in organizations that design LSCESs[68]. The completely mirrored structure represents the ideal structure that can be employed by an organization as per the

mirroring hypothesis[74-77]. Triangular distributions are used to represent organizational uncertainty on the satellite system. For the case study presented below, the lower and upper bounds of the triangular distributions were set at 10% lower and higher than the peak values respectively. Table 7.3 represents the number of specialization and coordination tasks required to perform a complete analysis and obtain the satellite system value.

Table 7.3: Task Execution for Satellite Subsystems

Subsystem	Pure Hierarchy Coordination	Completely Mirrored Coordination	Specialization
Comm. Satellite	95	0	1
Payload	4	2	2
Ground	1	1	1
Engine	11	9	9
Power	23	9	9
ADCS	12	21	7
Thermal	11	12	6
Structures	7	28	7
Launch Vehicle	9	9	9
Satellite Transponder	1	3	1
Satellite Antenna	3	1	1
Ground Transponder	1	1	1
Ground Antenna	3	1	1
Propellant	2	2	1
Power Source	5	10	5
Power Storage	1	3	1
Thermal Finish	1	2	1
Radiator & Heater	1	2	1
Bus Material	1	1	1
Satellite Transmitting Antenna	1	3	1

Table 7.3: (Continued)

Satellite Receiving Antenna	1	3	1
Ground Transmitting Antenna	1	2	1
Ground Receiving Antenna	1	2	1
Propellant Tank	1	2	1

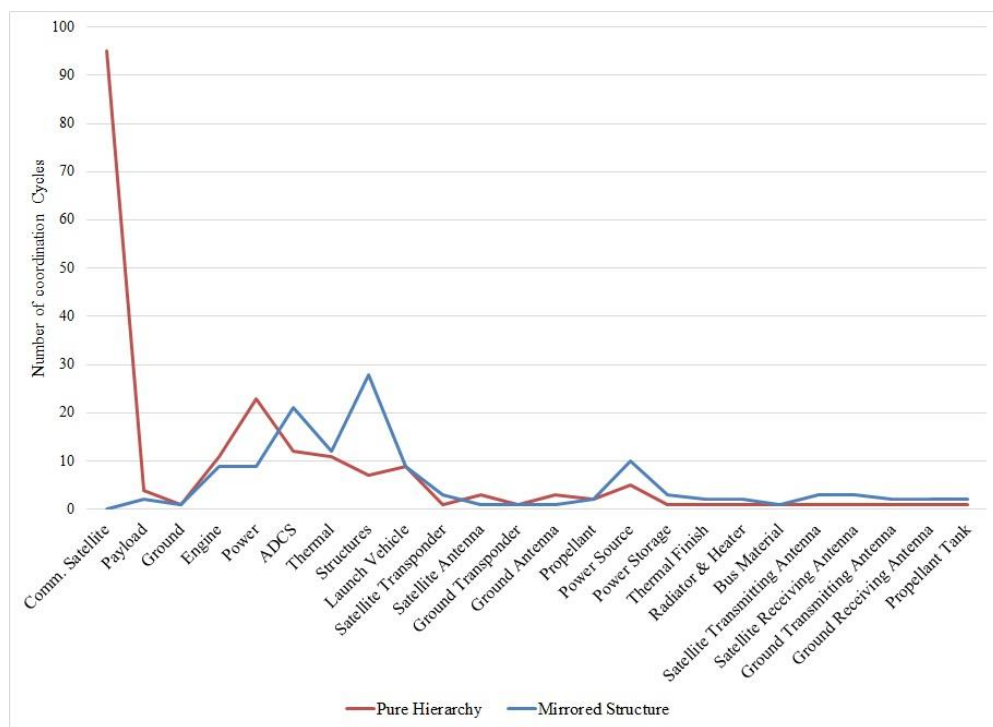

Figure 7.9: Coordination Effort within Organization Structures

The tabulation of the task execution as presented in Table 7.3 points to the differences between system evaluations for pure hierarchies and mirrored structures. Applicable to the system presented in Chapter 4, it is observed that the coordination effort associated with pure hierarchy structures is focused at higher subsystems within the hierarchy as opposed to a pure mirrored structure. The mirrored structure represents a greater spread of coordination effort and thereby

results in lower cost associated with the organization as discussed below. Fig. 7.9 illustrates this difference in the distribution of coordination effort throughout the system for both organization structures as discussed above.

Table 7.4: Satellite System Uncertainty Evaluation

Perceived NPP	\$307,225,290.61		
Expected NPP Pure Hierarchy	\$272,737,174.05	Range of Net Profit Pure Hierarchy	\$3,239,324.63
Expected NPP Mirroring	\$281,426,371.70	Range of Net Profit Mirroring	\$2,112,675.32
Expected Org Cost Pure Hierarchy	\$34,488,116.56	Range of Org Cost Pure Hierarchy	\$3,239,324.63
Expected Org Cost Mirroring	\$25,798,918.91	Range of Org Cost Mirroring	\$2,112,675.32
Expected Development Time Pure Hierarchy	3 yrs 5 months	Range of Development Time Pure Hierarchy	6 months
Expected Development Time Mirroring	2 yrs 7 months	Range of Development Time Mirroring	4 months

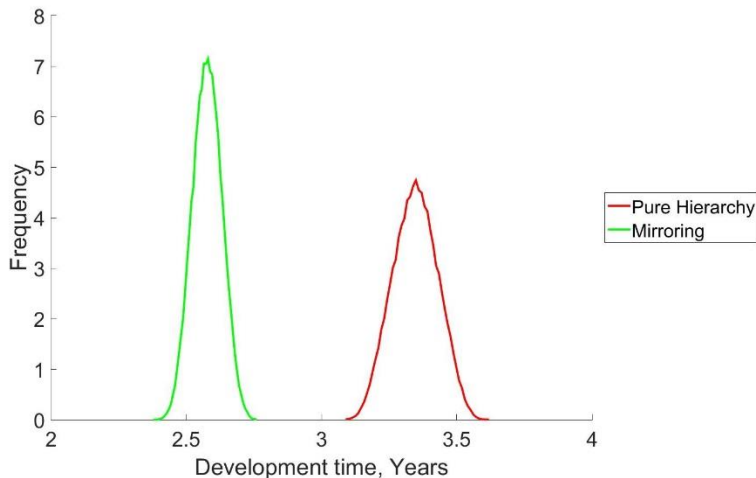

Figure 7.10: Satellite System Development Time

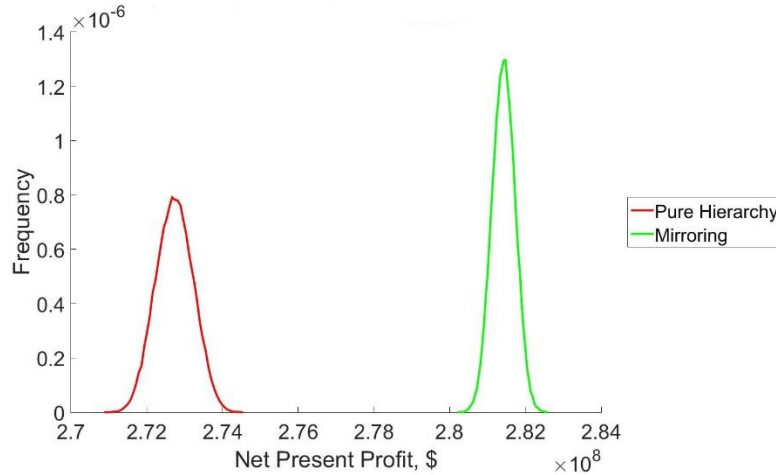

Figure 7.11: Satellite System Net Present Profit

Table 7.4 highlights features of the system value and development time distributions associated with the pure hierarchy and mirrored organization structures. In addition to the findings presented in Chapter 6, the value distributions provide a greater insight into the role that organization structures play on system value by virtue of task specialization and coordination. As illustrated in Fig. 7.10, using a mirrored organization structure in the presented value model would result in a shorter development time when compared to a pure hierarchy organization structure. An observation that is unique to the uncertainty analysis is the difference in system value uncertainty when comparing the application of both organization structures. The development time distribution has a larger range for the pure hierarchy than that for the mirrored structure. The range for system value is also larger for the pure hierarchy structure when compared to the mirrored structure as is observable in Fig. 7.11.

Based on the findings in this Chapter, the author believes that capturing uncertainty present in task execution within organizations allows for decision makers to gain information that aids in the decision making process[87]. The ability to do this can lead to better prediction of development efforts and lead to reduced budget overruns and delivery times. Additionally, the understanding of

the effects that uncertainty can have on system value can influence the formation of organization structures that drive development efforts. It would be possible to create mirroring within a structure where the highest levels of uncertainty exist to reduce the impact that uncertainty would have on overall system value given that, in this work, coordination tasks have a greater effect on system value uncertainty than specialization tasks.

CHAPTER 8: INFORMATION UNCERTAINTY

Following the capturing of organization structure uncertainty in the value modeling of complex systems as demonstrated in Chapter 7, this chapter highlights the author's efforts in capturing uncertainty of information and the perception of this information by decision makers within an organization. This provides a start to the research effort required to successfully develop a method to complete research objective 3 which addresses the need to capture the varied perception of information within organizations by different decision makers. Within organizations, power is distributed to decision makers at various levels in order to handle information and control decisions that are made by certain lower level decision makers[11, 68]. In this manner, the prescription of power to various decision makers provides the ability to accept decisions, conditionally accept or reject decisions made by those over whom they have power.

Where the design of complex engineered systems is concerned, the author breaks down the possible perception of information into three different scenarios. The acceptance of a decision maker's decision means the reception of information without any reservation regardless of the existence of any previous information. This can be viewed as a situation where there is complete trust in the information that is generated by a decision maker or the information that is delivered to a decision maker (100% trust). In an instance where a decision maker rejects the use of information that is relayed to them, the situation can be viewed as one where there is lack of trust between the sender and the recipient of the information (0% trust). The third situation is one in which a decision maker only partially accepts information that is relayed to them. We can consider this decision maker to have partial trust in the information relayed to them ($0% < \text{trust} < 100%$).

Upon identifying the three scenarios upon which information is perceived by a decision maker, the author separates the analyses of system design into two distinct groups: the handling of

information where information is deterministic in nature and is represented as a discrete outcome and that in which the information is uncertain and represented as probability distributions.

Discrete Information

Information generated as discrete outcomes can be handled by a receiving decision maker in one of three ways as discussed in the previous section. These are acceptance, conditional acceptance or rejection. If a value model is used in the design process of a complex engineered system, it is possible to capture the overall effect on the system via system value. The author uses the complex system that was introduced in Chapter 3 to demonstrate how a decision maker's trust in information affects system value where organization structure parameters are part of the value function of the complex system.

$$x' = c_r x_r + c_o x_o \quad (8.1)$$

where x' = expected/aggregate outcome

x_r = received outcome

x_o = reference outcome

c_r = factor of confidence in received outcome
information

c_o = factor of confidence in reference outcome
information

Eq. 8.1 provides a general function used to aggregate the information received with the information that previously existed in order to obtain usable information by the receiving decision maker. For this work, the confidence factors, c_r and c_o , exist between 0 and 1. In addition, they must add up to 1 to represent a summative trust of 100%.

The initial scenario mentioned is the complete acceptance of information where the received information is accepted as is thereby representing complete trust (100%). In this instance, c_r is equal to 1 and Eq. 8.1 is reduced to $x' = x_r$ as a result of having c_o equal 0. This scenario represents an ideal decision maker's perception of received information with regard to a given subsystem outcome. To illustrate this, the attribute $A_{2,2,1}$ in the system presented in Chapter 3 and

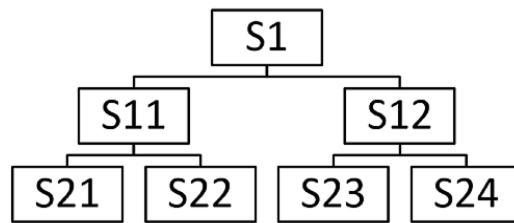

Figure 8.1: Sample Complex System Decomposition

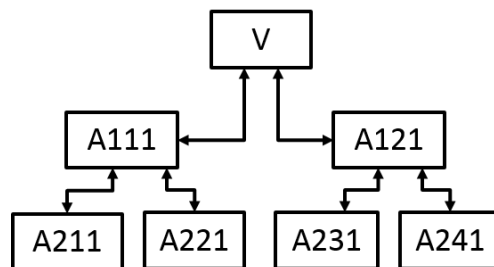

Figure 8.2: System Attributes to Fig. 8.1

pictured in Fig. 8.1 is subject to this scrutiny by the decision maker representing subsystem S21. Noteworthy to the analysis is subsystems S21 and S22 are completely coupled. This requires iteration between the two decision makers to reach consistent values for attributes $A_{2,1,1}$ and $A_{2,2,1}$. The design variable set used for the analysis is $(-2,3,-4,1,-5,2)$ which is an arbitrary selection. As demonstrated in Appendix B, there is a consistent relationship with regard to organization structure contribution to the system value based on the organization structure employed. The initial value

used for attribute $A_{2,2,1}$ in this design variable set is 1.8. The final value for the same attribute after a convergence of subsystems S21 and S22 is 28 with a total of 18 iterations. The overall system value for this design variable set is presented below in Table 8.1.

Table 8.1: System Value with Complete Trust

Organization Structure	System Value Without Development Time	System Value With Development Time
Pure Hierarchy	542.5471	349.2769
Complete Mirroring	548.3771	377.5851

As a second scenario that could present itself within an organization, a decision maker can disregard information that is received and intended to be used to determine system value. With regard to Eq. 8.1, this lack of trust in the new information would result in a c_o value of 1 and consequently a c_r value of 0. Eq. 8.1 is thusly reduced to $x' = x_o$. The result of this is a decoupling of the subsystems S21 and S22 where the information passed to S22 remains unchanged given that the information obtained from subsystem S22 is disregarded.

Table 8.2 highlights the various parameter values associated with the complex system where there exists a lack of trust in the information conveyed from the decision maker present in S22 to the decision maker present in S21. It is observed that there is a large deviation in system value that is a result of the rejection of information within the organization for both structures associated with the given design variable set and attribute selection. This demonstrates the potential for capturing discrepancies in system value associated with lack of trust within an organization.

Table 8.2: System Value with No Trust

Organization Structure	System Value With 100% Trust		System Value With 0% Trust	
	Without Development Time	With Development Time	Without Development Time	With Development Time
Pure Hierarchy	542.5471	349.2769	158.6301	124.0606
Complete Mirroring	548.3771	377.5851	161.7601	154.1082

The final scenario involves the conditional acceptance of information received by a decision maker. The design set used to demonstrate this scenario is the same as that associated with the first two scenarios. In this instance, both confidence factors c_r and c_o are non-zero numbers. This means that all entities in Eq. 8.1 are present to provide the final outcome, x' . Table 8.3 presents the various system values associated with the different confidence factors that represent conditional acceptance of information for the sample complex system that was presented in detail in Chapter 3 and is represented by Fig. 8.1 and Fig. 8.2. The results for this system and scenarios illustrate an exponential growth in the iterations required to converge the system values with regard to a decrease in the trust placed on the received information by the decision maker present in subsystem S21 as illustrated in Fig. 8.4. Fig 8.3 illustrated the exponential decrease in system value with a decrease in confidence of received information.

Table 8.3: System Value with Varying Trust

C_r	Pure Hierarchy System Value With Development Time	Complete Mirror System Value With Development Time	Iteration S21-S22
1.0	349.2769	377.5851	18
0.9	345.2356	369.8052	19
0.8	345.2356	369.8052	19
0.7	341.2404	362.1850	20
0.6	337.2909	354.7213	21
0.5	329.5273	340.2516	23

Table 8.3: (Continued)

0.4	309.2907	306.6045	28
0.3	272.4510	248.9550	38
0.2	208.6857	160.7300	59
0.1	94.7375	44.1119	121

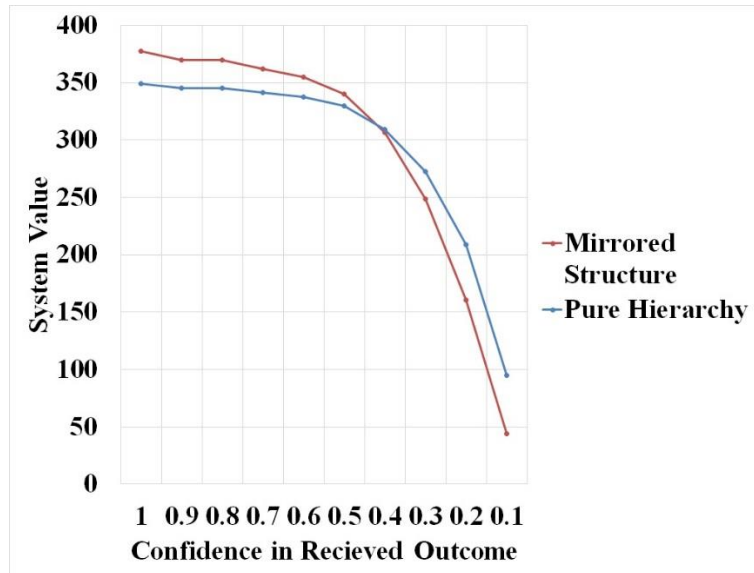

Figure 8.3: System Value with Variation of Confidence in Information

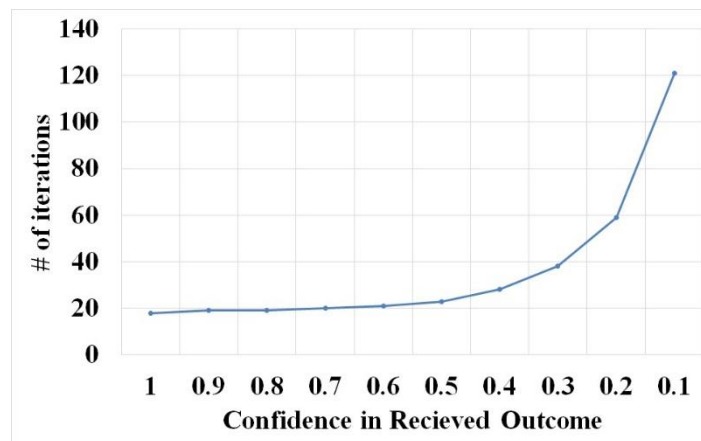

Figure 8.4: No. of iterations with Variation of Confidence in Information

Uncertainty Analysis

Where uncertainty exists in the information relayed in terms of a given range of values, probability distributions are used to represent this information in the design of engineered systems[1, 88-93]. In this section, the author uses probability distributions to represent the uncertainty of an information set and the effect on overall system value where the value model includes the organization parameters associated with including organization structures in the value modeling of complex engineered systems. To simplify the problem and allow the author to investigate the feasibility of capturing uncertainty in information within an organization, a design variable is used as opposed to a coupled behavior variable as was the case with the previous section investigating discrete outcomes.

For the system presented in Chapter 3 and illustrated in Fig. 8.1 and Fig. 8.2, the design variable xI is subject to uncertainty. This is accomplished by representing the design variable as a triangular distribution which is commonly used to represent normal distributions in engineering where there exists a finite upper and lower bound[94, 95]. Once identified, it becomes necessary to merge information. In this instance, Bayesian updating is used to combine the distribution associated with the prior belief on the design variable xI by the decision maker present in S11 with the new information (evidence) provided by the decision maker present in S21[96]. Eq. 8.2 represents the equation used to calculate the posterior probability distribution from the prior distribution and the evidential distribution.

$$p(\sigma_i|B) = \frac{p(\sigma_i)p(B|\sigma_i)}{\sum_{j=1}^k p(\sigma_j)p(B|\sigma_j)} \quad (8.2)$$

where $p(\sigma_i)$ = probability of prior belief

$p(B|\sigma_i)$ = probability of state i knowing B

$$p(x'_i) = \frac{p(x_{o,i})p(x_{r,i})}{\sum_{j=1}^k p(x_{o,j})p(x_{r,j})} \quad (8.3)$$

Eq. 8.3 represents the equation as it is applied to the complex system in question. Appendix C contains the tabulated design variable range and the various probabilities associated with each design variable value that make up the three probability distributions. These are the prior, evidential and posterior probability distributions. The system values are calculated for the entire design variable set keeping the other design variables (x_2, x_3, x_4, x_5, x_6) constant. Fig. 8.5 shows the three probability distributions that represent the three states of the design variable.

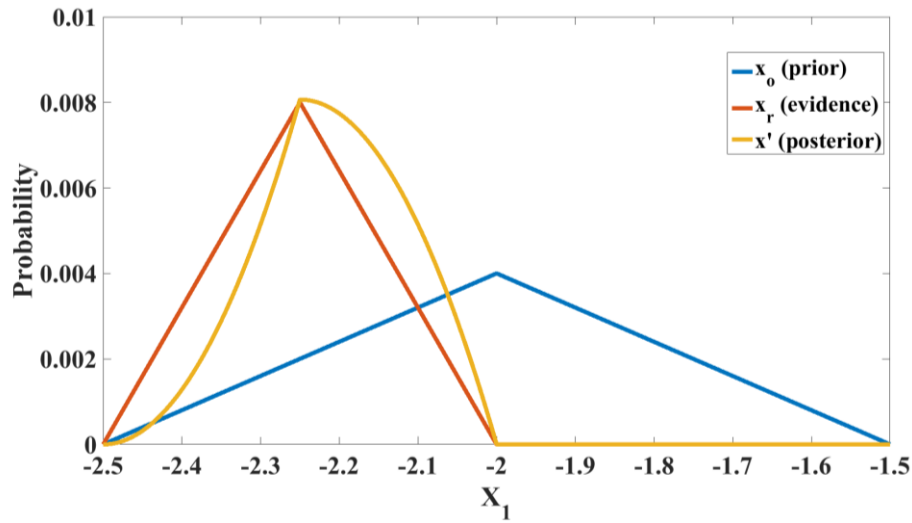

Figure 8.5: Design Variable X₁ Probability Distributions

For this analysis, all four organization structures introduced in Chapter 6 are used. However, the two structures that represent the two known extremes (pure hierarchy and complete mirroring) are presented. Fig. 8.6 represents the probability distributions of the system values associated with the complex system where the system design is subject to a pure hierarchy. Fig 8.7 on the other hand represents the probability distributions associated with the pure hierarchy organization structure where uncertainty exists on design variable x_7 . It is observed that the system

value with a pure hierarchy produces a higher expected value as well as a higher minimum and maximum value which would support the results obtained in both Chapters 6 and 7.

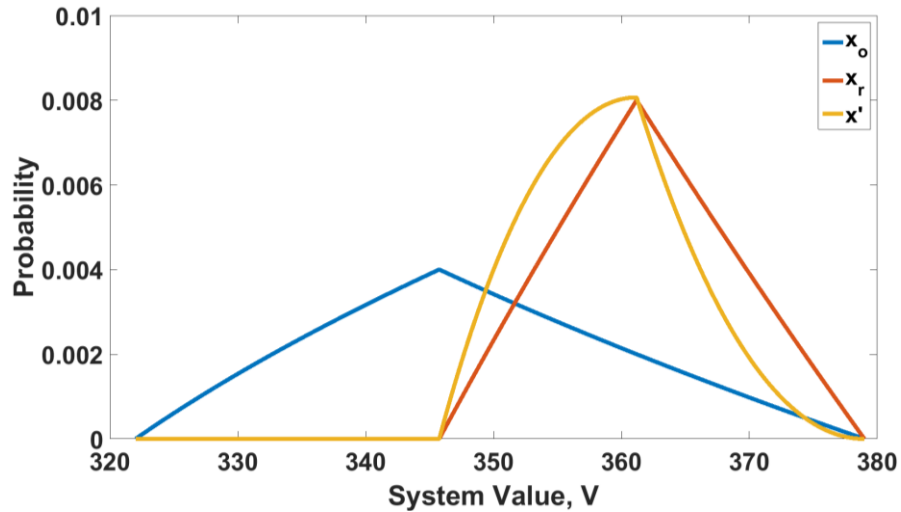

Figure 8.6: Mirrored Structure System Value Probability Distributions

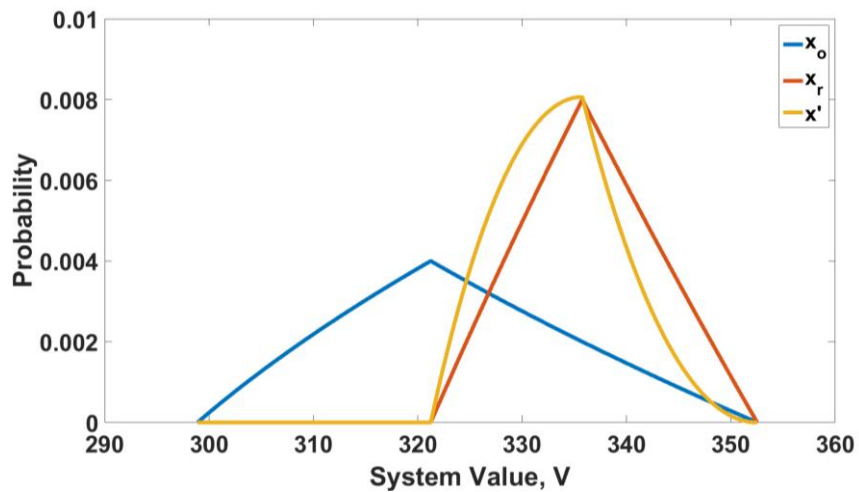

Figure 8.7: Pure Hierarchy System Value Probability Distributions

The use of Bayesian updating as presented herein with triangular distributions however does not produce meaningful results in a situation where the prior and evidence distributions do not overlap. A scenario where there is no overlap results in a probability of zero across the entire outcome range and therefore does not accurately reflect an engineering design environment. The author is currently conducting research to find an appropriate way to represent this in the value

modeling of LSCESs to improve the provision of information necessary for making sound decisions during the design and development of these systems.

CHAPTER 9: SUMMARY, CONCLUSION AND FUTURE WORK

Summary and Conclusion

Given the challenges faced in the design of LSCESs, the author attempts to merge Organization Design with a value-based approach to systems engineering. This effort is aimed at reducing scheduling delays and cost overruns. It is the opinion of the author that using this value-based approach to Systems Engineering will provide a platform for increased information that relates to an engineered system and increases the ability of decision makers to make decisions that correspond to system critical stakeholders' preferences.

In attempting to reach the goal stated above, this research has demonstrated the viability of capturing organization structure parameters in the value modeling of both a complex engineered system as well as an LSCES. It was demonstrated that the value modeling for these systems is achievable for both deterministic design as well as stochastic design. These findings provide the basis to have an approach to preliminary design as well as detailed design processes that is scalable. This means that the ability to include both product and process in the evaluation of a system can be used by individual teams within organizations or by entire organizations.

Future Work

Given the scalability and generalizability of this research, there exists a multitude of opportunities for future research work as well as for the application of this methodology in society. Work that can immediately follow is the investigation of increased relationships between OD and physics-based parameters and variables to potentially further improve models that aid the design for LSCESs. In addition to this, there is the opportunity to research a methodology to capture uncertainty in information relayed amongst decision makers within an organization that includes

non-overlapping probability distributions. This will be followed by the use of utility theory to address the decision making process adopted by different decision makers based on risk preferences.

In addition to the aforementioned, there exists a need to develop means to align decision makers' preferences to stakeholders' preferences in organizations. This will involve investigating gaps between stakeholders' and decision makers' preferences. The integration of Social Science concepts to bridge these preference gaps is one such example of the work that can improve the work presented by the author. One such possibility is the use of incentive theory to alter the perceived preferences of decision makers. The possibility of modeling systems with these added characteristics to provide improved decision making support will be explored. Research in the use of incentives to motivate people is the next step in understanding how to best encourage decision makers to act in the best interest of stakeholders based on stakeholder preferences.

Another opportunity that would follow this research work involves addressing organizations that work on the development of multiple complex systems. These organizations use matrix type team structures which are not explored extensively in Organization Design. Research work can be done to investigate the organization attributes that would appropriately capture the relationships between the matrix structures and the physics-based structures. These matrix structures present a challenge in preference communication as decision makers are forced to share limited resources. Game Theory is a discipline that will be one of the areas used to investigate preference communication where there are limited resources that create competition within an organization.

REFERENCES

1. Bloebaum, C.L. and A.-M.R. McGowan. *The Design of Large-Scale Complex Engineered Systems: Present Challenges and Future Promise*. in *12th AIAA ATIO Conference and 14th AIAA/ISSMO MA&O Conference*, AIAA Paper. 2012.
2. *The Design of Large-Scale Complex Engineered Systems: Present Challenges and Future Promise*, in *12th AIAA Aviation Technology, Integration, and Operations (ATIO) Conference and 14th AIAA/ISSMO Multidisciplinary Analysis and Optimization Conference*. 2012, American Institute of Aeronautics and Astronautics.
3. Griffin, M.D. *How do we fix System Engineering?* in *61st Annual International Congress*, Prague, Czech Republic. 2010.
4. DARPA/NSF, *DARPA/NSF Systems Engineering and Design of Complex Aerospace Systems Workshop*. 2009: Arlington, VA.
5. NSF. *Systems Science Program*. 2017; Available from: https://www.nsf.gov/funding/pgm_summ.jsp?pims_id=504788.
6. Bloebaum, C.L., P. Collopy, and G.A. Hazelrigg, *NSF/NASA Workshop on the Design of Large-Scale Complex Engineered Systems - From Research to Product Realization*, in *14th AIAA/ISSMO Multidisciplinary Analysis and Optimization Conference*. 2012: Indianapolis, Indiana.
7. Collopy, P., C.L. Bloebaum, and B.L. Mesmer. *The Distinct and Interrelated Roles of Value-Driven Design, Multidisciplinary Design Optimization, and Decision Analysis*. in *14th AIAA/ISSMO Multidisciplinary Analysis and Optimization Conference*. 2012.
8. DOE. *National Power Grid*. 2017; Available from: <https://energy.gov/articles/top-9-things-you-didnt-know-about-americas-power-grid>.
9. Harris, M. and A. Raviv, *Organization Design*. Management science, 2002. **48**(7): p. 852-865.
10. Mintzberg, H., *Structure in 5's: A Synthesis of the Research on Organization Design*. Management Science, 1980. **26**(3): p. 322-341.
11. March, J., *Organizations / James G. March and Herbert A. Simon ; with the collaboration of Harold Guetzkow*.
12. Company, T.B. *Boeing Employment Data*. 2017 March 30th, 2017; Available from: <http://www.boeing.com/company/general-info/>.
13. Nasa.gov. *NASA Workforce Data*. 2016 [cited 2016; Available from: https://wicn.nssc.nasa.gov/wicn_cubes.html.
14. Baligh, H.H., *Organization Structures: Theory and Design, Analysis and Prescription*. Information and Organization Design Series. 2006.
15. Braha, D. and Y. Bar-Yam, *Information flow structure in large-scale product development organizational networks*. Journal of Information Technology, 2004. **19**(4): p. 244-253.
16. Allen, J.K., S. Azarm, and T.W. Simpson, *Guest Editorial: Designing Complex Engineered Systems*. ASME Journal of Mechanical Design, 2011. **133**(10): p. 100301 (2pgs).
17. Buede, D.M., *The Engineering Design of Systems : Models and Methods*. 2009.
18. Calvano, C.N. and P. John, *Systems engineering in an age of complexity*. Systems Engineering, 2004. **7**(1): p. 25-34.
19. Hazelrigg, G.A., *A framework for decision-based engineering design*. Journal of mechanical design, 1998. **120**: p. 653.

20. INCOSE, *INCOSE Systems Engineering Handbook v3.2*. 2010, www.icose.org: International Council on Systems Engineering.
21. NASA, *NASA Systems Engineering Handbook*. Vol. NASA/SP-2007-6105 Rev1. 2007, Washington, D.C.
22. Ottino, J.M., *Engineering complex systems*. Nature, 2004. **427**(6973): p. 399-399.
23. Ryschkewitsch, M., D. Schaible, and W. Larson. *The art and science of systems engineering*. in *Systems Research Forum*. 2009. World Scientific.
24. Shishko, R., *NASA systems engineering handbook*. 1995.
25. Stevens, R. and P. Brook, *Systems engineering: coping with complexity*. 1998: Pearson Education.
26. Sobieszczanski-Sobieski, J., B.B. James, and M. Riley, *Structural Optimization by Generalized, Multilevel Decomposition*. NASA Technical Memorandum 87605, 1985.
27. Bloebaum, C., P. Hajela, and J. Sobieszczanski-Sobieski, *Non-hierarchical system decomposition in structural optimization*. Engineering Optimization+ A35, 1992. **19**(3): p. 171-186.
28. Balling, R.J. and J. Sobieszczanski-Sobieski, *OPTIMIZATION OF COUPLED SYSTEMS: A CRITICAL OVERVIEW OF APPROACHES*. 1994, Institute for Computer Applications in Science and Engineering (ICASE).
29. Sobieszczanski-Sobieski, J. and R.T. Haftka, *Multidisciplinary aerospace design optimization: survey of recent developments*. Structural and Multidisciplinary Optimization, 1997. **14**(1): p. 1-23.
30. Sobieszczanski-Sobieski, J., *Sensitivity of complex, internally coupled systems*. AIAA journal, 1990. **28**(1): p. 153-160.
31. Yi, S.I., J.K. Shin, and G.J. Park, *Comparison of MDO methods with mathematical examples*. Structural and Multidisciplinary Optimization, 2008. **35**(5): p. 391-402.
32. Cramer, E.J., et al., *Problem formulation for multidisciplinary optimization*. SIAM Journal on Optimization, 1994. **4**(4): p. 754-776.
33. McCulley, C. and C. Bloebaum, *Comparison of heuristic convergence strategies for multidisciplinary analysis*. AIAA, 1998. **4943**: p. 1-11.
34. Taylor, E.R. *Evaluation of multidisciplinary design optimization techniques as applied to spacecraft design*. in *Aerospace Conference Proceedings, 2000 IEEE*. 2000.
35. English, K., C. Bloebaum, and E. Miller, *Development of multiple cycle coupling suspension in the optimization of complex systems*. Structural and Multidisciplinary Optimization, 2001. **22**(4): p. 268-283.
36. Yi, S.-I., J.-K. Shin, and G. Park, *Comparison of MDO methods with mathematical examples*. Structural and Multidisciplinary Optimization, 2008. **35**(5): p. 391-402.
37. Rogers, J.L. and C.L. Bloebaum, *Ordering design tasks based on coupling strengths*. 1994: Citeseer.
38. McCulley, C. and C. Bloebaum. *Optimal sequencing for complex engineering systems using genetic algorithms*. in *A Collection of Papers, 5th AIAA/USAF/NASA/ISSMO Symposium on Multidisciplinary Analysis and Optimization*. 1994.
39. Bloebaum, C., *Coupling strength-based system reduction for complex engineering design*. Structural Optimization, 1995. **10**(2): p. 113-121.
40. Hajela, P., C.L. Bloebaum, and J. Sobieszczanski-Sobieski, *Application of global sensitivity equations in multidisciplinary aircraft synthesis*. Journal of Aircraft, 1990. **27**(12): p. 1002-1010.

41. McCulley, C. and C.L. Bloebaum, *A genetic tool for optimal design sequencing in complex engineering systems*. Structural optimization, 1996. **12**(2-3): p. 186-201.
42. McCulley, C., K. Hulme, and C. Bloebaum, *Simulation-based development of heuristic strategies for complex system convergence*. Feedback, 1997. **3**: p. 4.
43. English, K., E. Miller, and C. Bloebaum. *Total derivative based coupling suspension for system reduction in complex design*. in *Proc. of the Sixth AIAA/USAF/NASA/OAI Symposium on Multidisciplinary Analysis and Optimization*, Seattle, WA. 1996.
44. Carrascosa, M., S.D. Eppinger, and D.E. Whitney. *Using the design structure matrix to estimate product development time*. in *Proceedings of the ASME Design Engineering Technical Conferences (Design Automation Conference)*. 1998.
45. Browning, T.R., *Applying the design structure matrix to system decomposition and integration problems: a review and new directions*. Engineering Management, IEEE Transactions on, 2001. **48**(3): p. 292-306.
46. Yassine, A. and D. Braha, *Complex concurrent engineering and the design structure matrix method*. Concurrent Engineering, 2003. **11**(3): p. 165-176.
47. Sharman, D.M. and A.A. Yassine, *Characterizing complex product architectures*. Systems Engineering, 2004. **7**(1): p. 35-60.
48. English, K.W. and C.L. Bloebaum, *Visual dependency structure matrix for multidisciplinary design optimization tradeoff studies*. Journal of Aerospace Computing, Information, and Communication, 2008. **5**(9): p. 274-297.
49. Collopy, P. and R. Horton, *Value Modelling for Technology Evaluation*. 2002.
50. Collopy, P., *Value Driven Design and the Global Positioning System*. 2006.
51. Richard, C., et al., *Value Operations Methodology for Value Driven Design: Medium Range Passenger Airliner Validation*, in *48th AIAA Aerospace Sciences Meeting Including the New Horizons Forum and Aerospace Exposition*. 2010, American Institute of Aeronautics and Astronautics.
52. Curran, R., *Value-Driven Design and Operational Value*, in *Encyclopedia of Aerospace Engineering*. 2010, John Wiley & Sons, Ltd.
53. Collopy, P.D. and P.M. Hollingsworth, *Value-driven design*. Journal of Aircraft, 2011. **48**(3): p. 749-759.
54. Hollingsworth, P. *An investigation of value modelling for commercial aircraft*. in *Air Transport and Operations: Proceedings of the Second International Air Transport and Operations Symposium 2011*. 2011. Ios PressInc.
55. Goossens, H., W.B. Van Blokland, and R. Curran. *The Development and Application of a Value-Driven Aircraft Maintenance Operations Performance Assessment Model combined with Real Options Analysis*. in *11th AIAA Aviation Technology, Integration, and Operations (ATIO) Conference, including the AIAA Balloon Systems Conference and 19th AIAA Lighter-Than*. 2011.
56. Collopy, P.D. and C. Poleacovschi. *Validating Value-Driven Design*. in *Air Transport and Operations: Proceedings of the Third International Air Transport and Operations Symposium 2012*. 2012. IOS Press.
57. Collopy, P.D., *Aerospace system value models: A survey and observations*. AIAA Paper, 2009. **6560**: p. 2009.
58. Cheung, J., et al., *Application of Value-Driven Design to Commercial AeroEngine Systems*. Journal of Aircraft, 2012. **49**(3): p. 688-702.

59. Heng, S.S., et al. *Value Driven Design in Automotive Transport Systems*. in *Air Transport and Operations: Proceedings of the Third International Air Transport and Operations Symposium 2012*. 2012. IOS Press.
60. Miller, S., et al., *Toward a Value-Driven Design Approach for Complex Engineering Systems using Trade Space Exploration Tools*, in *Submitted to the ASME 2014 International Design Engineering Technical Conferences & Computers and Information in Engineering Conference*. 2014: Buffalo, NY.
61. Kannan, H., *An MDO augmented value-based systems engineering approach to holistic design decision-making: a satellite system case study*, in *Aerospace Engineering*. 2015, Iowa State University. p. 169.
62. Andrea, H., et al., *Calculating Value Gaps Induced by Independent Requirements, Deterministic Modeling, and Fixed Targets*, in *56th AIAA/ASCE/AHS/ASC Structures, Structural Dynamics, and Materials Conference*. 2015, American Institute of Aeronautics and Astronautics.
63. Murugaiyan, S., Kannan, H., Mesmer, B., Abbas, A.E., Bloebaum, C.L., *A Comprehensive Study on Modeling Requirements into Value Formulation in a Satellite System Application*, in *Conference on Systems Engineering Research (CSER)*. 2016: Huntsville, AL.
64. Mesmer, B.L., C.L. Bloebaum, and H. Kannan, *Incorporation of Value-Driven Design in Multidisciplinary Design Optimization*, in *10th World Congress of Structural and Multidisciplinary Optimization (WCSMO)*. 2013: Orlando, Florida.
65. Mesmer, B., C.L. Bloebaum, and H. Kannan, *Incorporation of Value-Driven Design in Multidisciplinary Design Optimization for a Satellite System Application*. submitted to *Structural and Multidisciplinary Optimization*, 2014.
66. Kannan, H., C.L. Bloebaum, and B.L. Mesmer. *Incorporation of Risk Preferences in a Value-Based Systems Engineering Framework for a Satellite System*. in *18th AIAA Non-Deterministic Approaches Conference*. 2016.
67. Galbraith, J., *Organization design / Jay R. Galbraith*.
68. Child, J., *Predicting and Understanding Organization Structure*. *Administrative Science Quarterly*, 1973. **18**(2): p. 168-185.
69. RD, B. and K. IM, *Development and application of the collaborative optimization architecture in a multidisciplinary design environment*. 1995.
70. Yu, E.S. *Modeling organizations for information systems requirements engineering*. in *Requirements Engineering, 1993., Proceedings of IEEE International Symposium on*. 1993. IEEE.
71. Sosa, M.E., S.D. Eppinger, and C.M. Rowles, *The misalignment of product architecture and organizational structure in complex product development*. *Management science*, 2004. **50**(12): p. 1674-1689.
72. Avnet, M.S., *Socio-cognitive analysis of engineering systems design: shared knowledge, process, and product*. 2009, Massachusetts Institute of Technology.
73. Tripathy, A. and S.D. Eppinger, *Organizing global product development for complex engineered systems*. *Engineering Management, IEEE Transactions on*, 2011. **58**(3): p. 510-529.
74. MacCormack, A.D., J. Rusnak, and C.Y. Baldwin, *Exploring the duality between product and organizational architectures: A test of the mirroring hypothesis*. 2008: Citeseer.
75. Colfer, L. and C.Y. Baldwin, *The mirroring hypothesis: Theory, evidence and exceptions*. Harvard Business School, 2010: p. 10-058.

76. MacCormack, A., C. Baldwin, and J. Rusnak, *Exploring the duality between product and organizational architectures: A test of the "mirroring" hypothesis*. Research Policy, 2012. **41**(8): p. 1309-1324.
77. Cabigiosu, A. and A. Camuffo, *Beyond the "mirroring" hypothesis: Product modularity and interorganizational relations in the air conditioning industry*. Organization Science, 2012. **23**(3): p. 686-703.
78. Agarwal, K., *Physics Based Hierarchical Decomposition of Processes for Design of Complex Engineered Systems*. 2011, Ohio State University.
79. Benjamin, K., L.B. Christina, and M. Bryan, *Value Impact of an Organization Structure in the Context of Value-Driven Design*, in *56th AIAA/ASCE/AHS/ASC Structures, Structural Dynamics, and Materials Conference*. 2015, American Institute of Aeronautics and Astronautics.
80. Steward, D.V., *Systems analysis and management: structure, strategy and design*. 1981: PBI (New York).
81. Kelley Jr, J.E. and M.R. Walker. *Critical-path planning and scheduling*. in *Papers presented at the December 1-3, 1959, eastern joint IRE-AIEE-ACM computer conference*. 1959. ACM.
82. Thuesen, H.G., W.J. Fabrycky, and G.J. Thuesen, *Engineering economy*. 1971: Prentice Hall.
83. Chandra, M.J. and M.L. Bahner, *The effects of inflation and the time value of money on some inventory systems*. International Journal of Production Research, 1985. **23**(4): p. 723-730.
84. Kwasa, B. and H. Kannan. *IMPACT OF ORGANIZATION STRUCTURE ON THE VALUE OF A SYSTEM IN SYSTEMS ENGINEERING*. in *Proceedings of the International Annual Conference of the American Society for Engineering Management*. 2015.
85. Kwasa, B., Kannan, H., Bloebaum C.L., *Impact of Organization Structure on the Value of a Commercial Communication Satellite*, in *Conference on Systems Engineering Research (CSER)*. 2016: Huntsville, AL.
86. Tables, I.E., *Introduction to probability and statistics*. 1972.
87. Kwasa, B., Kannan, H., Bloebaum C.L., *Capturing Organizational Uncertainty in a Value-Based Systems Engineering Framework*, in *American Society of Engineering Management International Annual Conference*. 2016.
88. Bayes, T., *An Essay towards solving a Problem in the Doctrine of Chances*. Philosophical Transactions, 1763. **53**: p. 370-418.
89. Du, X. and W. Chen. *An efficient approach to probabilistic uncertainty analysis in simulation-based multidisciplinary design*. in *the 38th AIAA aerospace sciences meeting and exhibit, Reno, Nevada*. AIAA-2000-0423. 2000.
90. Smith, N. and S. Mahadevan, *Probabilistic methods for aerospace system conceptual design*. Journal of spacecraft and rockets, 2003. **40**(3): p. 411-418.
91. Kokkolaras, M., Z.P. Mourelatos, and P.Y. Papalambros, *Design optimization of hierarchically decomposed multilevel systems under uncertainty*. Journal of Mechanical Design, 2006. **128**: p. 503.
92. Sun, J., et al., *Multi-disciplinary design optimization under uncertainty for thermal protection system applications*. AAIA Paper, 2006: p. 7002-547.

93. Hassan, R. and W. Crossley, *Spacecraft reliability-based design optimization under uncertainty including discrete variables*. Journal of Spacecraft and Rockets, 2008. **45**(2): p. 394-405.
94. Johnson, D., *The triangular distribution as a proxy for the beta distribution in risk analysis*. Journal of the Royal Statistical Society: Series D (The Statistician), 1997. **46**(3): p. 387-398.
95. Ren é van Dorp, J. and S. Kotz, *A novel extension of the triangular distribution and its parameter estimation*. Journal of the Royal Statistical Society: Series D (The Statistician), 2002. **51**(1): p. 63-79.
96. Vapnik, V.N. and V. Vapnik, *Statistical learning theory*. Vol. 1. 1998: Wiley New York.

APPENDIX A

SATELLITE SYSTEM VARIABLES AND PARAMETERS

This section lists all the design variables and parameters that were necessary to create the communication satellite model which was done by Dr. Kannan[61, 65]. The variables used for the VDD/MDO value function calculations are shown in the following table.

Variables and Parameters	Description	Type	Value
A	Rain attenuation in dB	Calculated	----
A_{bus}	Surface area of the Spacecraft bus	Calculated	----
A_{cr}	Cross sectional area of the bus in m^2	Calculated	----
$A_{sat\ trans}$	Surface area of satellite transmitting antenna	Calculated	----
$A_{sat\ rec}$	Surface area of satellite receiving antenna	Calculated	----
$A_{p,SA}$	Projected area of the insulated layers of Solar array	Calculated	----
$A_{p,sat\ trans}$	Projected area of the insulated layers of Satellite transmitting antenna	Calculated	----
$A_{p,sat\ rec}$	Projected area of the insulated layers of Satellite receiving antenna	Calculated	----
$A_{p,bus}$	Projected area of the insulated layers of Spacecraft bus	Calculated	----
$A_{radiator,battery}$	Area of radiator for battery	Calculated	----
$A_{radiator,RW}$	Area of radiator for reaction wheel	Calculated	----
$A_{radiator,proptank}$	Area of radiator for propellant tank	Calculated	----

A_s	Surface area of the satellite	Calculated	----
BM	Bending moment	Calculated	----
C_{ADCS}	Cost of ADCS	Calculated	----
$C_{g,ant}$	Cost of ground antennae	Calculated	----
$C_{g,transmitter}$	Cost of ground transmitter	Calculated	----
$C_{ground\ support}$	Cost of ground support and operations	Calculated	----
$C_{integration,test,assembly}$	Cost of integration, test and assembly	Calculated	----
C_{lv}	Cost of launch vehicle	Calculated	----
$C_{payload}$	Cost of payload	Calculated	----
C_{power}	Cost of power system	Calculated	----
$C_{propulsion}$	Cost of propulsion system	Calculated	----
$C_{structures}$	Cost of structures	Calculated	----
$C_{thermal}$	Cost of thermal system	Calculated	----
DOD	Depth of discharge	Referenced	0.8
E	Young's modulus	Referenced	71.7 GPa
$FOS_{ultimate}$	Ultimate factor of safety	Referenced	1.6
FOS_{yield}	Yield factor of safety	Referenced	1.4
F_s	Solar flux	Constant	1367 W/m ²
F_{tu}	Ultimate tensile strength	Referenced	572 MPa
F_{ty}	Yield tensile strength	Referenced	503 MPa
$F_{ultimate}$	Ultimate load	Calculated	----

$G_{\text{ground,rec}}$	Ground receiving antenna gain	Calculated	----
$G_{\text{ground,trans}}$	Ground transmitting antenna gain	Calculated	----
$G_{\text{sat,rec}}$	Satellite receiving antenna gain	Calculated	----
$G_{\text{sat,trans}}$	Satellite transmitting antenna gain	Calculated	----
H	Discharging efficiency	Assumed	94%
I_{SP}	Specific Impulse of the propulsion system in seconds	Assumed	300 s
$I_{\text{SP,lv}}$	Specific Impulse of launch vehicle in seconds	Assumed	300 s
I_x	Mass moment of inertia of the spacecraft along the x-axis in $\text{kg}\cdot\text{m}^2$	Calculated	----
I_y	Mass moment of inertia of the spacecraft along the y-axis in $\text{kg}\cdot\text{m}^2$	Calculated	----
I_z	Mass moment of inertia of the spacecraft along the z-axis in $\text{kg}\cdot\text{m}^2$	Calculated	----
K_b	Boltzmann constant	Constant	$1.3807 \times 10^{-23} \text{ m}^2\text{kg} / \text{s}^2\text{K}$
L_a	Transmission path loss		0.890
L_{axial}	Axial load factor	Referenced	6
L_{BM}	Bending moment load factor	Referenced	3
L_l	Lateral load factor	Referenced	3
$L_{l,r}$	Line loss between receiver & antenna	Assumed	0.89
$L_{l,t}$	Line loss between transmitter & antenna	Assumed	0.89
$L_{\text{S,down}}$	Space loss (downlink)	Calculated	----

$L_{S,up}$	Space loss (uplink)	Calculated	----
M_B	Burnout mass considered in propulsion system in kg	Calculated	----
$M_{B,lv}$	Burnout mass considered in the launch vehicle in kg	Calculated	----
M_{dry}	Dry mass of the spacecraft in kg	Calculated	----
M_{ins}	Mass of insulator	Calculated	----
$M_{propellant,lv}$	Mass of propellant needed to get to GTO from launch station in kg	Calculated	----
$M_{radiator}$	Mass of radiator in kg	Calculated	----
$M_{sensors}$	Mass of attitude sensors in kg	Referenced	3 kg
$M_{structures}$	Mass of the bus including the masses of only the subsystems inside the bus in kg	Calculated	----
MS	Margin of Safety	Calculated	----
$M_{S/C}$	Spacecraft Mass in kg	Calculated	----
P_0	Power required by all the subsystems in W	Calculated	----
P_{axial}	Axial load	Calculated	----
P_{cr}	Critical buckling load	Calculated	----
P_{eq}	Equivalent load	Calculated	----
$P_{heater,battery}$	Power required by heater for battery	Calculated	----
$P_{heater,RW}$	Power required by heater for reaction wheel	Calculated	----
$P_{heater,proptank}$	Power required by heater for propellant tank	Calculated	----

P_{RW}	Power needed by RW motor	Calculated	----
P_{SA}	Required solar array output in W	Calculated	----
$P_{sensors}$	Power needed by sensors	Assumed	10 W
P_{st}	Satellite transmitter power	Assumed	30 W
PF	Packing factor	Referenced	0.9
Q_{int}	Internal heat generated	Assumed	400 W
R	Desired data rate	Assumed	8 Mbps
R_M	Mass ratio	Calculated	----
r	Radius of the orbit	Calculated	----
R_E	Radius of earth	Constant	6374.4 km
R_{lv}	Mass ratio for launch vehicle	Calculated	----
$SNR_{composite}$	Composite Signal to Noise ratio	Calculated	----
SNR_{down}	Signal to Noise ratio (downlink)	Calculated	----
SNR_{up}	Signal to Noise ratio (uplink)	Calculated	----
T_D	Total disturbance torque	Calculated	----
T_E	Maximum eclipse time	Referenced	1.2 hours
T_g	Gravity-gradient torque	Calculated	----
$T_{bus,max}$	Maximum operating temperature of spacecraft bus	Referenced	50° C
$T_{batt,max}$	Maximum operating temperature of battery	Referenced	15° C
$T_{RW,max}$	Maximum operating temperature of reaction wheel	Referenced	50° C

$T_{\text{sensors,max}}$	Maximum operating temperature of attitude sensors	Referenced	30° C
$T_{\text{proptank,max}}$	Maximum operating temperature of the propellant tank	Referenced	40° C
$T_{\text{sat trans,max}}$	Maximum operating temperature of the transmitting antenna	Referenced	100° C
$T_{\text{sat rec,max}}$	Maximum operating temperature of receiving antenna	Referenced	100° C
$T_{\text{SA,max}}$	Maximum operating temperature of the solar array	Referenced	110° C
$T_{\text{batt,min}}$	Minimum operating temperature of battery	Referenced	0° C
$T_{\text{RW,min}}$	Minimum operating temperature of reaction wheel	Referenced	-10° C
$T_{\text{sensors,min}}$	Minimum operating temperature of attitude sensors	Referenced	0° C
$T_{\text{proptank,min}}$	Minimum operating temperature of propellant tank	Referenced	15° C
$T_{\text{antenna,min}}$	Minimum operating temperature of both the antennae (receiving and transmitting)	Referenced	-100° C
$T_{\text{SA,min}}$	Minimum operating temperature of the solar array	Referenced	-150° C
T_o	Total orbital period	Constant	24 hours
T_{RW}	Reaction wheel torque needed	Calculated	----
T_s	Maximum sunlit time	Calculated	----
$T_{\text{s,down}}$	System noise temperature (downlink)	Referenced	424 K
T_{SP}	Torque due to solar radiation	Calculated	----

$T_{s,up}$	System noise temperature (uplink)	Referenced	614 K
V_{bus}	Volume of the satellite bus in m^3	Calculated	----
V_{sub}	Sum of volume of all subsystems inside the bus in m^3	Calculated	----
b_{SA}	Width of solar array	Calculated	----
c	Velocity of light	Constant	$2.9978 \times 10^8 m/s$
deg	Degradation	Assumed	0.3
eff_{cell}	Cell efficiency	Assumed	14%
$f_{nat,a}$	Natural frequency along axial direction	Referenced	25 Hz
$f_{nat,l}$	Natural frequency along lateral direction	Referenced	15 Hz
g_e	Acceleration due to gravity on the surface of earth	Constant	$9.81 m/s^2$
h_0	Orbital altitude	Constant	35786 m
h_c	Charging efficiency		92%
h	Total angular momentum needed	Calculated	----
h_D	Angular momentum needed to counter disturbance torques	Calculated	----
h_p	Angular momentum needed for pointing accuracy	Calculated	----
i	Sun incidence angle	Referenced	23.5°
l_{SA}	Length of solar array	Calculated	----
q	Surface sensitivity of the satellite	Referenced	0.6

r	Distance from the center of earth to the satellite in m	Calculated	----
temp	Temperature effect	Calculated	----
t_o	Operating temperature of solar panels	Referenced	60°C
$t_{ground,trans}$	Thickness of ground transmitting antenna in m	Assumed	0.1 m
$t_{ground,rec}$	Thickness of ground receiving antenna in m	Assumed	0.1 m
t_{ref}	Reference temperature	Referenced	28°C
t_{SA}	Thickness of solar array		0.03 m
$t_{req,1}$	Thickness required for ultimate strength	Calculated	----
$t_{req,2}$	Thickness required for yield strength	Calculated	----
$t_{sat,rec}$	Thickness of satellite receiving antenna	Assumed	0.03 m
$t_{sat,trans}$	Thickness of satellite transmitting antenna	Assumed	0.03 m
t_1	Thickness to meet the axial natural frequency requirement	Calculated	----
t_2	Thickness to meet the lateral natural frequency requirement	Calculated	----
α	Absorptivity of the insulating material	Calculated	----

$\frac{\alpha}{\varepsilon}$	Ratio between absorptivity and emissivity of the insulating material	Referenced	0.5
ΔV	Change in velocity needed to get to Geo-stationary orbit from Geo transfer orbit (GTO) and to make orbital and attitude corrections	Assumed	2000 m/s
ΔV_{LEO}	Delta-V required to get to Geo transfer orbit (GTO) from launch station	Assumed	10000 m/s
ε	Emissivity of the insulating material	Calculated	----
γ	Parameter 1 for calculating buckling stress	Calculated	----
ε_{rad}	Emissivity of the radiator	Assumed	0.8
$\eta_{ground,rec}$	Ground receiving antenna efficiency	Assumed	60%
$\eta_{ground,trans}$	Ground transmitting antenna efficiency	Assumed	60%
$\eta_{sat,trans}$	Satellite transmitting antenna efficiency	Assumed	60%
$\eta_{sat,rec}$	Satellite receiving antenna efficiency	Assumed	60%
θ	Maximum deviation from the vertical	Assumed	1°
θ_d	Pointing accuracy needed	Assumed	0.1°
λ_{down}	Downlink wavelength in m	Calculated	----
λ_{up}	Uplink wavelength in m	Calculated	----
μ	Gravitational constant of earth	Constant	$3.986 \times 10^{14} \text{m}^3/\text{s}^2$
ρ	Density of the material used for satellite bus	Referenced	2810 kg/m ³

$\rho_{Battery}$	Density of the battery	Referenced	3500 kg/m ³
ρ_{RW}	Density of reaction wheel material	Referenced	2800 kg/m ³
ρ_{prop}	Density of the propellant	Referenced	1021 kg/m ³
$\rho_{ground,rec}$	Density of ground receiving antenna in kg	Referenced	2800 $\frac{kg}{m^3}$
$\rho_{ground,trans}$	Density of ground transmitting antenna in kg	Referenced	2800 $\frac{kg}{m^3}$
$\rho_{sat,rec}$	Density of satellite receiving antenna in kg	Referenced	2800 $\frac{kg}{m^3}$
$\rho_{sat,trans}$	Density of satellite transmitting antenna in kg	Referenced	2800 $\frac{kg}{m^3}$
ρ_{trans}	Density of satellite transponders	Referenced	2700 $\frac{kg}{m^3}$
σ	Stefan Boltzmann constant	Constant	5.67051 $\times 10^{-8} Wm^{-2}K^{-4}$
σ_{cr}	Buckling stress	Calculated	----
ϕ	Parameter 2 for calculating buckling stress	Calculated	----

APPENDIX B

SAMPLE SYSTEM DESIGN SPACE SURVEY

The table below presents the design variable sets that are used to survey the system value throughout the design space for the system with varying organization structures.

Design Variable Sets Used to Survey Design Space for Complex System						
Design Set	x1	x2	x3	x4	x5	x6
1	5	5	5	5	5	5
2	4	4	4	4	4	4
3	3	3	3	3	3	3
4	2	2	2	2	2	2
5	1	1	1	1	1	1
6	0	0	0	0	0	0
7	-1	-1	-1	-1	-1	-1
8	-2	-2	-2	-2	-2	-2
9	-3	-3	-3	-3	-3	-3
10	-4	-4	-4	-4	-4	-4
11	-5	-5	-5	-5	-5	-5
12	3	-4	5	1	-2	1
13	-4	1	1	-1	2	-3
14	2	1	-3	-3	4	2
15	3	3	1	1	-2	0.5
16	1.1	2.5	3.1	2.2	-0.7	-3.1

17	2.8	-3.1	-4.2	-0.1	0.1	1.5
18	4.8	-3.2	-1.1	0.5	1.2	1.7
19	1.1	-2.3	-0.8	5	2.9	3.3
20	-2	3	-4	1	-5	2

The table below presents the system values for the various design sets presented above in terms of value with varying organization structures.

Design Set	Org. Structure (Mirrored Link)	System Value w/o Dev. Time	System Value w/ Dev. Time	Δ in System Value	Δ in System Value w/ Dev. Time	% Δ in System Value w/o Dev. Time	% Δ in System Value w/ Dev. Time
1	Pure Hierarchy	1318.8000	460.9493	0.0000	0.0000	0.00%	0.00%
	Complete Mirror	1332.9000	507.5274	14.1000	46.5781	1.07%	10.10%
	Partial Mirror (A241 – A111)	1332.6000	506.8990	13.8000	45.9497	1.05%	9.97%
	Partial Mirror (A211 – A231)	1332.9000	507.5084	14.1000	46.5591	1.07%	10.10%
2	Pure Hierarchy	792.8500	277.1190	0.0000	0.0000	0.00%	0.00%
	Complete Mirror	806.9300	307.2473	14.0800	30.1283	1.78%	10.87%

	Partial Mirror (A241 – A111)	806.6500	306.8248	13.8000	29.7058	1.74%	10.72%
	Partial Mirror (A211 – A231)	806.8800	307.2282	14.0300	30.1092	1.77%	10.87%
3	Pure Hierarchy	393.8200	140.7566	0.0000	0.0000	0.00%	0.00%
	Complete Mirror	407.6000	158.5225	13.7800	17.7659	3.50%	12.62%
	Partial Mirror (A241 – A111)	407.3200	158.2507	13.5000	17.4941	3.43%	12.43%
	Partial Mirror (A211 – A231)	407.5500	158.5031	13.7300	17.7465	3.49%	12.61%
4	Pure Hierarchy	121.7600	45.5172	0.0000	0.0000	0.00%	0.00%
	Complete Mirror	134.9400	54.7529	13.1800	9.2357	10.82%	20.29%
	Partial Mirror (A241 – A111)	134.6600	54.5831	12.9000	9.0659	10.59%	19.92%
	Partial Mirror (A211 – A231)	134.8900	54.7326	13.1300	9.2154	10.78%	20.25%
5	Pure Hierarchy	-22.3100	-9.0693	0.0000	0.0000	0.00%	0.00%

	Complete Mirror	-10.3300	-4.6505	11.9800	4.4188	53.70%	48.72%
	Partial Mirror (A241 – A111)	-10.6100	-4.7716	11.7000	4.2977	52.44%	47.39%
	Partial Mirror (A211 – A231)	-10.3800	-4.6730	11.9300	4.3963	53.47%	48.47%
6	Pure Hierarchy	-45.8400	-18.0792	0.0000	0.0000	0.00%	0.00%
	Complete Mirror	-33.4100	-14.1579	12.4300	3.9213	27.12%	21.69%
	Partial Mirror (A241 – A111)	-33.6900	-14.2619	12.1500	3.8173	26.51%	21.11%
	Partial Mirror (A211 – A231)	-33.4600	-14.1791	12.3800	3.9001	27.01%	21.57%
7	Pure Hierarchy	56.7300	21.7001	0.0000	0.0000	0.00%	0.00%
	Complete Mirror	69.6100	28.8498	12.8800	7.1497	22.70%	32.95%
	Partial Mirror (A241 – A111)	69.3300	28.7042	12.6000	7.0041	22.21%	32.28%
	Partial Mirror (A211 – A231)	69.5600	28.8291	12.8300	7.1290	22.62%	32.85%

8	Pure Hierarchy	284.7900	104.0833	0.0000	0.0000	0.00%	0.00%
	Complete Mirror	298.2700	118.4871	13.4800	14.4038	4.73%	13.84%
	Partial Mirror (A241 – A111)	297.9900	118.2541	13.2000	14.1708	4.63%	13.61%
	Partial Mirror (A211 – A231)	298.2200	118.4672	13.4300	14.3839	4.72%	13.82%
9	Pure Hierarchy	639.8200	228.6250	0.0000	0.0000	0.00%	0.00%
	Complete Mirror	653.6000	254.1961	13.7800	25.5711	2.15%	11.18%
	Partial Mirror (A241 – A111)	653.3200	253.8259	13.5000	25.2009	2.11%	11.02%
	Partial Mirror (A211 – A231)	653.5500	254.1766	13.7300	25.5516	2.15%	11.18%
10	Pure Hierarchy	1120.8000	391.7508	0.0000	0.0000	0.00%	0.00%
	Complete Mirror	1134.9000	432.1368	14.1000	40.3860	1.26%	10.31%
	Partial Mirror (A241 – A111)	1134.6000	431.5859	13.8000	39.8351	1.23%	10.17%

	Partial Mirror (A211 – A231)	1134.9000	432.1178	14.1000	40.3670	1.26%	10.30%
11	Pure Hierarchy	1727.9000	590.6275	0.0000	0.0000	0.00%	0.00%
	Complete Mirror	1742.3000	649.4721	14.4000	58.8446	0.83%	9.96%
	Partial Mirror (A241 – A111)	1742.0000	648.7000	14.1000	58.0725	0.82%	9.83%
	Partial Mirror (A211 – A231)	1742.2000	649.4535	14.3000	58.8260	0.83%	9.96%
12	Pure Hierarchy	512.8200	183.2802	0.0000	0.0000	0.00%	0.00%
	Complete Mirror	526.6000	204.8036	13.7800	21.5234	2.69%	11.74%
	Partial Mirror (A241 – A111)	526.3200	204.4843	13.5000	21.2041	2.63%	11.57%
	Partial Mirror (A211 – A231)	526.5500	204.7842	13.7300	21.5040	2.68%	11.73%
13	Pure Hierarchy	265.7900	97.1413	0.0000	0.0000	0.00%	0.00%
	Complete Mirror	279.2700	110.9394	13.4800	13.7981	5.07%	14.20%

	Partial Mirror (A241 – A111)	278.9900	110.7142	13.2000	13.5729	4.97%	13.97%
	Partial Mirror (A211 – A231)	279.2200	110.9195	13.4300	13.7782	5.05%	14.18%
14	Pure Hierarchy	366.3300	132.3419	0.0000	0.0000	0.00%	0.00%
	Complete Mirror	379.9600	150.7831	13.6300	18.4412	3.72%	13.93%
	Partial Mirror (A241 – A111)	379.6800	150.5170	13.3500	18.1751	3.64%	13.73%
	Partial Mirror (A211 – A231)	379.9100	150.7632	13.5800	18.4213	3.71%	13.92%
15	Pure Hierarchy	516.3200	184.5309	0.0000	0.0000	0.00%	0.00%
	Complete Mirror	530.1000	206.1649	13.7800	21.6340	2.67%	11.72%
	Partial Mirror (A241 – A111)	529.8200	205.8441	13.5000	21.3132	2.61%	11.55%
	Partial Mirror (A211 – A231)	530.0500	206.1454	13.7300	21.6145	2.66%	11.71%
16	Pure Hierarchy	12.5700	4.7806	0.0000	0.0000	0.00%	0.00%

	Complete Mirror	25.6000	10.3981	13.0300	5.6175	103.66%	117.51%
	Partial Mirror (A241 – A111)	25.3200	10.2738	12.7500	5.4932	101.43%	114.91%
	Partial Mirror (A211 – A231)	25.5500	10.3778	12.9800	5.5972	103.26%	117.08%
17	Pure Hierarchy	867.7000	303.2781	0.0000	0.0000	0.00%	0.00%
	Complete Mirror	881.7800	335.7472	14.0800	32.4691	1.62%	10.71%
	Partial Mirror (A241 – A111)	881.5000	335.2955	13.8000	32.0174	1.59%	10.56%
	Partial Mirror (A211 – A231)	881.7300	335.7282	14.0300	32.4501	1.62%	10.70%
18	Pure Hierarchy	1195.3000	417.7667	0.0000	0.0000	0.00%	0.00%
	Complete Mirror	1209.4000	460.4806	14.1000	42.7139	1.18%	10.22%
	Partial Mirror (A241 – A111)	1209.1000	459.9006	13.8000	42.1339	1.15%	10.09%
	Partial Mirror (A211 – A231)	1209.3000	460.4616	14.0000	42.6949	1.17%	10.22%

19	Pure Hierarchy	228.2600	83.4289	0.0000	0.0000	0.00%	0.00%
	Complete Mirror	241.7400	96.0307	13.4800	12.6018	5.91%	15.10%
	Partial Mirror (A241 – A111)	241.4600	95.8208	13.2000	12.3919	5.78%	14.85%
	Partial Mirror (A211 – A231)	241.6900	96.0108	13.4300	12.5819	5.88%	15.08%
20	Pure Hierarchy	516.8200	184.7096	0.0000	0.0000	0.00%	0.00%
	Complete Mirror	530.6000	206.3593	13.7800	21.6497	2.67%	11.72%
	Partial Mirror (A241 – A111)	530.3200	206.0383	13.5000	21.3287	2.61%	11.55%
	Partial Mirror (A211 – A231)	530.5500	206.3399	13.7300	21.6303	2.66%	11.71%

APPENDIX C PROBABILITY DISTRIBUTION UPDATING

This represents the design variable probability distribution for the prior design variable belief, the new evidence and the posterior distribution associated with design variable $x1$.

x1	p(x1_prior)	p(x1_new evidence)	p(x1_posterior)
-2.5	0	0	0
-2.498	1.6E-05	6.4E-05	5.12E-07
-2.496	3.2E-05	0.000128	2.05E-06
-2.494	4.8E-05	0.000192	4.61E-06
-2.492	6.4E-05	0.000256	8.19E-06
-2.49	8E-05	0.00032	1.28E-05
-2.488	9.6E-05	0.000384	1.84E-05
-2.486	0.000112	0.000448	2.51E-05
-2.484	0.000128	0.000512	3.28E-05
-2.482	0.000144	0.000576	4.15E-05
-2.48	0.00016	0.00064	5.12E-05
-2.478	0.000176	0.000704	6.2E-05
-2.476	0.000192	0.000768	7.37E-05
-2.474	0.000208	0.000832	8.65E-05
-2.472	0.000224	0.000896	0.0001
-2.47	0.00024	0.00096	0.000115
-2.468	0.000256	0.001024	0.000131
-2.466	0.000272	0.001088	0.000148
-2.464	0.000288	0.001152	0.000166

-2.462	0.000304	0.001216	0.000185
-2.46	0.00032	0.00128	0.000205
-2.458	0.000336	0.001344	0.000226
-2.456	0.000352	0.001408	0.000248
-2.454	0.000368	0.001472	0.000271
-2.452	0.000384	0.001536	0.000295
-2.45	0.0004	0.0016	0.00032
-2.448	0.000416	0.001664	0.000346
-2.446	0.000432	0.001728	0.000373
-2.444	0.000448	0.001792	0.000402
-2.442	0.000464	0.001856	0.000431
-2.44	0.00048	0.00192	0.000461
-2.438	0.000496	0.001984	0.000492
-2.436	0.000512	0.002048	0.000525
-2.434	0.000528	0.002112	0.000558
-2.432	0.000544	0.002176	0.000592
-2.43	0.00056	0.00224	0.000628
-2.428	0.000576	0.002304	0.000664
-2.426	0.000592	0.002368	0.000701
-2.424	0.000608	0.002432	0.00074
-2.422	0.000624	0.002496	0.000779
-2.42	0.00064	0.00256	0.00082
-2.418	0.000656	0.002624	0.000861

-2.416	0.000672	0.002688	0.000904
-2.414	0.000688	0.002752	0.000948
-2.412	0.000704	0.002816	0.000992
-2.41	0.00072	0.00288	0.001038
-2.408	0.000736	0.002944	0.001085
-2.406	0.000752	0.003008	0.001132
-2.404	0.000768	0.003072	0.001181
-2.402	0.000784	0.003136	0.001231
-2.4	0.0008	0.0032	0.001282
-2.398	0.000816	0.003264	0.001333
-2.396	0.000832	0.003328	0.001386
-2.394	0.000848	0.003392	0.00144
-2.392	0.000864	0.003456	0.001495
-2.39	0.00088	0.00352	0.001551
-2.388	0.000896	0.003584	0.001608
-2.386	0.000912	0.003648	0.001666
-2.384	0.000928	0.003712	0.001725
-2.382	0.000944	0.003776	0.001785
-2.38	0.00096	0.00384	0.001847
-2.378	0.000976	0.003904	0.001909
-2.376	0.000992	0.003968	0.001972
-2.374	0.001008	0.004032	0.002036
-2.372	0.001024	0.004096	0.002102

-2.37	0.00104	0.00416	0.002168
-2.368	0.001056	0.004224	0.002235
-2.366	0.001072	0.004288	0.002304
-2.364	0.001088	0.004352	0.002373
-2.362	0.001104	0.004416	0.002444
-2.36	0.00112	0.00448	0.002515
-2.358	0.001136	0.004544	0.002588
-2.356	0.001152	0.004608	0.002661
-2.354	0.001168	0.004672	0.002736
-2.352	0.001184	0.004736	0.002812
-2.35	0.0012	0.0048	0.002888
-2.348	0.001216	0.004864	0.002966
-2.346	0.001232	0.004928	0.003045
-2.344	0.001248	0.004992	0.003125
-2.342	0.001264	0.005056	0.003206
-2.34	0.00128	0.00512	0.003288
-2.338	0.001296	0.005184	0.003371
-2.336	0.001312	0.005248	0.003455
-2.334	0.001328	0.005312	0.00354
-2.332	0.001344	0.005376	0.003626
-2.33	0.00136	0.00544	0.003713
-2.328	0.001376	0.005504	0.003801
-2.326	0.001392	0.005568	0.00389

-2.324	0.001408	0.005632	0.003981
-2.322	0.001424	0.005696	0.004072
-2.32	0.00144	0.00576	0.004164
-2.318	0.001456	0.005824	0.004258
-2.316	0.001472	0.005888	0.004352
-2.314	0.001488	0.005952	0.004448
-2.312	0.001504	0.006016	0.004545
-2.31	0.00152	0.00608	0.004642
-2.308	0.001536	0.006144	0.004741
-2.306	0.001552	0.006208	0.004841
-2.304	0.001568	0.006272	0.004942
-2.302	0.001584	0.006336	0.005043
-2.3	0.0016	0.0064	0.005146
-2.298	0.001616	0.006464	0.00525
-2.296	0.001632	0.006528	0.005355
-2.294	0.001648	0.006592	0.005461
-2.292	0.001664	0.006656	0.005569
-2.29	0.00168	0.00672	0.005677
-2.288	0.001696	0.006784	0.005786
-2.286	0.001712	0.006848	0.005896
-2.284	0.001728	0.006912	0.006008
-2.282	0.001744	0.006976	0.00612
-2.28	0.00176	0.00704	0.006234

-2.278	0.001776	0.007104	0.006348
-2.276	0.001792	0.007168	0.006464
-2.274	0.001808	0.007232	0.006581
-2.272	0.001824	0.007296	0.006699
-2.27	0.00184	0.00736	0.006817
-2.268	0.001856	0.007424	0.006937
-2.266	0.001872	0.007488	0.007058
-2.264	0.001888	0.007552	0.00718
-2.262	0.001904	0.007616	0.007303
-2.26	0.00192	0.00768	0.007428
-2.258	0.001936	0.007744	0.007553
-2.256	0.001952	0.007808	0.007679
-2.254	0.001968	0.007872	0.007807
-2.252	0.001984	0.007936	0.007935
-2.25	0.002	0.008	0.008065
-2.248	0.002016	0.007936	0.008064
-2.246	0.002032	0.007872	0.008062
-2.244	0.002048	0.007808	0.00806
-2.242	0.002064	0.007744	0.008056
-2.24	0.00208	0.00768	0.008052
-2.238	0.002096	0.007616	0.008046
-2.236	0.002112	0.007552	0.008039
-2.234	0.002128	0.007488	0.008031

-2.232	0.002144	0.007424	0.008022
-2.23	0.00216	0.00736	0.008012
-2.228	0.002176	0.007296	0.008002
-2.226	0.002192	0.007232	0.00799
-2.224	0.002208	0.007168	0.007977
-2.222	0.002224	0.007104	0.007963
-2.22	0.00224	0.00704	0.007947
-2.218	0.002256	0.006976	0.007931
-2.216	0.002272	0.006912	0.007914
-2.214	0.002288	0.006848	0.007896
-2.212	0.002304	0.006784	0.007877
-2.21	0.00232	0.00672	0.007856
-2.208	0.002336	0.006656	0.007835
-2.206	0.002352	0.006592	0.007813
-2.204	0.002368	0.006528	0.007789
-2.202	0.002384	0.006464	0.007765
-2.2	0.0024	0.0064	0.007739
-2.198	0.002416	0.006336	0.007713
-2.196	0.002432	0.006272	0.007685
-2.194	0.002448	0.006208	0.007657
-2.192	0.002464	0.006144	0.007627
-2.19	0.00248	0.00608	0.007596
-2.188	0.002496	0.006016	0.007565

-2.186	0.002512	0.005952	0.007532
-2.184	0.002528	0.005888	0.007498
-2.182	0.002544	0.005824	0.007463
-2.18	0.00256	0.00576	0.007428
-2.178	0.002576	0.005696	0.007391
-2.176	0.002592	0.005632	0.007353
-2.174	0.002608	0.005568	0.007314
-2.172	0.002624	0.005504	0.007274
-2.17	0.00264	0.00544	0.007233
-2.168	0.002656	0.005376	0.007191
-2.166	0.002672	0.005312	0.007148
-2.164	0.002688	0.005248	0.007103
-2.162	0.002704	0.005184	0.007058
-2.16	0.00272	0.00512	0.007012
-2.158	0.002736	0.005056	0.006965
-2.156	0.002752	0.004992	0.006917
-2.154	0.002768	0.004928	0.006867
-2.152	0.002784	0.004864	0.006817
-2.15	0.0028	0.0048	0.006765
-2.148	0.002816	0.004736	0.006713
-2.146	0.002832	0.004672	0.00666
-2.144	0.002848	0.004608	0.006605
-2.142	0.002864	0.004544	0.00655

-2.14	0.00288	0.00448	0.006493
-2.138	0.002896	0.004416	0.006436
-2.136	0.002912	0.004352	0.006377
-2.134	0.002928	0.004288	0.006317
-2.132	0.002944	0.004224	0.006257
-2.13	0.00296	0.00416	0.006195
-2.128	0.002976	0.004096	0.006132
-2.126	0.002992	0.004032	0.006068
-2.124	0.003008	0.003968	0.006004
-2.122	0.003024	0.003904	0.005938
-2.12	0.00304	0.00384	0.005871
-2.118	0.003056	0.003776	0.005803
-2.116	0.003072	0.003712	0.005734
-2.114	0.003088	0.003648	0.005664
-2.112	0.003104	0.003584	0.005593
-2.11	0.00312	0.00352	0.005522
-2.108	0.003136	0.003456	0.005449
-2.106	0.003152	0.003392	0.005375
-2.104	0.003168	0.003328	0.005299
-2.102	0.003184	0.003264	0.005223
-2.1	0.0032	0.0032	0.005146
-2.098	0.003216	0.003136	0.005068
-2.096	0.003232	0.003072	0.004989

-2.094	0.003248	0.003008	0.004909
-2.092	0.003264	0.002944	0.004828
-2.09	0.00328	0.00288	0.004746
-2.088	0.003296	0.002816	0.004662
-2.086	0.003312	0.002752	0.004578
-2.084	0.003328	0.002688	0.004493
-2.082	0.003344	0.002624	0.004407
-2.08	0.00336	0.00256	0.004319
-2.078	0.003376	0.002496	0.004231
-2.076	0.003392	0.002432	0.004142
-2.074	0.003408	0.002368	0.004051
-2.072	0.003424	0.002304	0.00396
-2.07	0.00344	0.00224	0.003868
-2.068	0.003456	0.002176	0.003774
-2.066	0.003472	0.002112	0.00368
-2.064	0.003488	0.002048	0.003585
-2.062	0.003504	0.001984	0.003488
-2.06	0.00352	0.00192	0.003391
-2.058	0.003536	0.001856	0.003292
-2.056	0.003552	0.001792	0.003193
-2.054	0.003568	0.001728	0.003092
-2.052	0.003584	0.001664	0.002991
-2.05	0.0036	0.0016	0.002888

-2.048	0.003616	0.001536	0.002785
-2.046	0.003632	0.001472	0.00268
-2.044	0.003648	0.001408	0.002575
-2.042	0.003664	0.001344	0.002468
-2.04	0.00368	0.00128	0.002361
-2.038	0.003696	0.001216	0.002252
-2.036	0.003712	0.001152	0.002143
-2.034	0.003728	0.001088	0.002032
-2.032	0.003744	0.001024	0.001921
-2.03	0.00376	0.00096	0.001808
-2.028	0.003776	0.000896	0.001695
-2.026	0.003792	0.000832	0.00158
-2.024	0.003808	0.000768	0.001464
-2.022	0.003824	0.000704	0.001348
-2.02	0.00384	0.00064	0.00123
-2.018	0.003856	0.000576	0.001112
-2.016	0.003872	0.000512	0.000992
-2.014	0.003888	0.000448	0.000872
-2.012	0.003904	0.000384	0.00075
-2.01	0.00392	0.00032	0.000628
-2.008	0.003936	0.000256	0.000504
-2.006	0.003952	0.000192	0.00038
-2.004	0.003968	0.000128	0.000254

-2.002	0.003984	6.4E-05	0.000128
-2	0.004	1.92E-15	3.84E-15
-1.998	0.003984	0	0
-1.996	0.003968	0	0
-1.994	0.003952	0	0
-1.992	0.003936	0	0
-1.99	0.00392	0	0
-1.988	0.003904	0	0
-1.986	0.003888	0	0
-1.984	0.003872	0	0
-1.982	0.003856	0	0
-1.98	0.00384	0	0
-1.978	0.003824	0	0
-1.976	0.003808	0	0
-1.974	0.003792	0	0
-1.972	0.003776	0	0
-1.97	0.00376	0	0
-1.968	0.003744	0	0
-1.966	0.003728	0	0
-1.964	0.003712	0	0
-1.962	0.003696	0	0
-1.96	0.00368	0	0
-1.958	0.003664	0	0

-1.956	0.003648	0	0
-1.954	0.003632	0	0
-1.952	0.003616	0	0
-1.95	0.0036	0	0
-1.948	0.003584	0	0
-1.946	0.003568	0	0
-1.944	0.003552	0	0
-1.942	0.003536	0	0
-1.94	0.00352	0	0
-1.938	0.003504	0	0
-1.936	0.003488	0	0
-1.934	0.003472	0	0
-1.932	0.003456	0	0
-1.93	0.00344	0	0
-1.928	0.003424	0	0
-1.926	0.003408	0	0
-1.924	0.003392	0	0
-1.922	0.003376	0	0
-1.92	0.00336	0	0
-1.918	0.003344	0	0
-1.916	0.003328	0	0
-1.914	0.003312	0	0
-1.912	0.003296	0	0

-1.91	0.00328	0	0
-1.908	0.003264	0	0
-1.906	0.003248	0	0
-1.904	0.003232	0	0
-1.902	0.003216	0	0
-1.9	0.0032	0	0
-1.898	0.003184	0	0
-1.896	0.003168	0	0
-1.894	0.003152	0	0
-1.892	0.003136	0	0
-1.89	0.00312	0	0
-1.888	0.003104	0	0
-1.886	0.003088	0	0
-1.884	0.003072	0	0
-1.882	0.003056	0	0
-1.88	0.00304	0	0
-1.878	0.003024	0	0
-1.876	0.003008	0	0
-1.874	0.002992	0	0
-1.872	0.002976	0	0
-1.87	0.00296	0	0
-1.868	0.002944	0	0
-1.866	0.002928	0	0

-1.864	0.002912	0	0
-1.862	0.002896	0	0
-1.86	0.00288	0	0
-1.858	0.002864	0	0
-1.856	0.002848	0	0
-1.854	0.002832	0	0
-1.852	0.002816	0	0
-1.85	0.0028	0	0
-1.848	0.002784	0	0
-1.846	0.002768	0	0
-1.844	0.002752	0	0
-1.842	0.002736	0	0
-1.84	0.00272	0	0
-1.838	0.002704	0	0
-1.836	0.002688	0	0
-1.834	0.002672	0	0
-1.832	0.002656	0	0
-1.83	0.00264	0	0
-1.828	0.002624	0	0
-1.826	0.002608	0	0
-1.824	0.002592	0	0
-1.822	0.002576	0	0
-1.82	0.00256	0	0

-1.818	0.002544	0	0
-1.816	0.002528	0	0
-1.814	0.002512	0	0
-1.812	0.002496	0	0
-1.81	0.00248	0	0
-1.808	0.002464	0	0
-1.806	0.002448	0	0
-1.804	0.002432	0	0
-1.802	0.002416	0	0
-1.8	0.0024	0	0
-1.798	0.002384	0	0
-1.796	0.002368	0	0
-1.794	0.002352	0	0
-1.792	0.002336	0	0
-1.79	0.00232	0	0
-1.788	0.002304	0	0
-1.786	0.002288	0	0
-1.784	0.002272	0	0
-1.782	0.002256	0	0
-1.78	0.00224	0	0
-1.778	0.002224	0	0
-1.776	0.002208	0	0
-1.774	0.002192	0	0

-1.772	0.002176	0	0
-1.77	0.00216	0	0
-1.768	0.002144	0	0
-1.766	0.002128	0	0
-1.764	0.002112	0	0
-1.762	0.002096	0	0
-1.76	0.00208	0	0
-1.758	0.002064	0	0
-1.756	0.002048	0	0
-1.754	0.002032	0	0
-1.752	0.002016	0	0
-1.75	0.002	0	0
-1.748	0.001984	0	0
-1.746	0.001968	0	0
-1.744	0.001952	0	0
-1.742	0.001936	0	0
-1.74	0.00192	0	0
-1.738	0.001904	0	0
-1.736	0.001888	0	0
-1.734	0.001872	0	0
-1.732	0.001856	0	0
-1.73	0.00184	0	0
-1.728	0.001824	0	0

-1.726	0.001808	0	0
-1.724	0.001792	0	0
-1.722	0.001776	0	0
-1.72	0.00176	0	0
-1.718	0.001744	0	0
-1.716	0.001728	0	0
-1.714	0.001712	0	0
-1.712	0.001696	0	0
-1.71	0.00168	0	0
-1.708	0.001664	0	0
-1.706	0.001648	0	0
-1.704	0.001632	0	0
-1.702	0.001616	0	0
-1.7	0.0016	0	0
-1.698	0.001584	0	0
-1.696	0.001568	0	0
-1.694	0.001552	0	0
-1.692	0.001536	0	0
-1.69	0.00152	0	0
-1.688	0.001504	0	0
-1.686	0.001488	0	0
-1.684	0.001472	0	0
-1.682	0.001456	0	0

-1.68	0.00144	0	0
-1.678	0.001424	0	0
-1.676	0.001408	0	0
-1.674	0.001392	0	0
-1.672	0.001376	0	0
-1.67	0.00136	0	0
-1.668	0.001344	0	0
-1.666	0.001328	0	0
-1.664	0.001312	0	0
-1.662	0.001296	0	0
-1.66	0.00128	0	0
-1.658	0.001264	0	0
-1.656	0.001248	0	0
-1.654	0.001232	0	0
-1.652	0.001216	0	0
-1.65	0.0012	0	0
-1.648	0.001184	0	0
-1.646	0.001168	0	0
-1.644	0.001152	0	0
-1.642	0.001136	0	0
-1.64	0.00112	0	0
-1.638	0.001104	0	0
-1.636	0.001088	0	0

-1.634	0.001072	0	0
-1.632	0.001056	0	0
-1.63	0.00104	0	0
-1.628	0.001024	0	0
-1.626	0.001008	0	0
-1.624	0.000992	0	0
-1.622	0.000976	0	0
-1.62	0.00096	0	0
-1.618	0.000944	0	0
-1.616	0.000928	0	0
-1.614	0.000912	0	0
-1.612	0.000896	0	0
-1.61	0.00088	0	0
-1.608	0.000864	0	0
-1.606	0.000848	0	0
-1.604	0.000832	0	0
-1.602	0.000816	0	0
-1.6	0.0008	0	0
-1.598	0.000784	0	0
-1.596	0.000768	0	0
-1.594	0.000752	0	0
-1.592	0.000736	0	0
-1.59	0.00072	0	0

-1.588	0.000704	0	0
-1.586	0.000688	0	0
-1.584	0.000672	0	0
-1.582	0.000656	0	0
-1.58	0.00064	0	0
-1.578	0.000624	0	0
-1.576	0.000608	0	0
-1.574	0.000592	0	0
-1.572	0.000576	0	0
-1.57	0.00056	0	0
-1.568	0.000544	0	0
-1.566	0.000528	0	0
-1.564	0.000512	0	0
-1.562	0.000496	0	0
-1.56	0.00048	0	0
-1.558	0.000464	0	0
-1.556	0.000448	0	0
-1.554	0.000432	0	0
-1.552	0.000416	0	0
-1.55	0.0004	0	0
-1.548	0.000384	0	0
-1.546	0.000368	0	0
-1.544	0.000352	0	0

-1.542	0.000336	0	0
-1.54	0.00032	0	0
-1.538	0.000304	0	0
-1.536	0.000288	0	0
-1.534	0.000272	0	0
-1.532	0.000256	0	0
-1.53	0.00024	0	0
-1.528	0.000224	0	0
-1.526	0.000208	0	0
-1.524	0.000192	0	0
-1.522	0.000176	0	0
-1.52	0.00016	0	0
-1.518	0.000144	0	0
-1.516	0.000128	0	0
-1.514	0.000112	0	0
-1.512	9.6E-05	0	0
-1.51	8E-05	0	0
-1.508	6.4E-05	0	0
-1.506	4.8E-05	0	0
-1.504	3.2E-05	0	0
-1.502	1.6E-05	0	0
-1.5	8.79E-16	0	0
	1	1	1.005906